



QUALYSGUARD[®] SCANNER APPLIANCE USER GUIDE

February 2, 2012



Copyright 2002-2012 by Qualys, Inc. All Rights Reserved.

Qualys, the Qualys logo and QualysGuard are registered trademarks of Qualys, Inc. All other trademarks are the property of their respective owners.

Qualys, Inc.
1600 Bridge Parkway
Redwood Shores, CA 94065
1 (650) 801 6100

CONTENTS

Preface

Chapter 1 Scanner Appliance Installation

Before You Begin	8
Package Accessories	8
Rack Mount Instructions	8
Managed Power Supply	8
Review Network Requirements	9
Scanning and Firewalls	9
Network Traffic Options	10
Physical Requirements	10
QualysGuard Account	10
Quick Start	11
Step 1 — Connect the Scanner Appliance to the Network	11
Step 2 — Power On the Scanner Appliance	13
Step 3 — Activate the Scanner Appliance	15
Log into the Scanner Appliance (Version 2.2)	15
Enter the Activation Code (Version 2.4 or later)	17
Quick Start Complete	18
Proper System Shutdown	18
Qualys Secure Global Architecture	19
What's Next	20

Chapter 2 Set Up Using QualysGuard

Check Scanner Appliance Status	22
Edit Scanner Appliance Settings	24
Grant Users Access to a Scanner Appliance	26
Replace Scanner Appliance	27

Chapter 3 Scanner Appliance Tour

Becoming Familiar with the Appliance	30
About the LCD Display	33
About the Remote Console Interface	33
Menus and Navigation	34
System Reboot and Shutdown	42
Qualys User/Password Store (Version 2.2)	44
VLAN Interface Configuration	45
Static IP Address Configuration	47
Proxy Configuration	51
Split Network Configuration	56

Contents

Ethernet Port Configuration.....	60
Reset the Network Configuration.....	62
Changing the Network Configuration.....	63

Appendix A Interface Maps

Login Procedure — Version 2.2	66
Interface Map — Version 2.2	67
Interface Map — Version 2.6 or later	68
Menus and User Configurations.....	69

Appendix B Troubleshooting

Network Configuration Guidelines	72
Testing Network Connectivity	73
“Network Error” Message	74
“Activation Code–Network Err.” Message.....	74
Network Error Codes	74
Network Error Solutions.....	75
“Login to Qualys–Guard Web First” Message	76
“Authentication Failure” Message	77
“Communication Failure” Message	78
Proxy Support.....	78
LAN and WAN LEDs.....	79

Appendix C Safety Notices

Appendix D Credits

Index

Preface

This user guide introduces the QualysGuard® Scanner Appliance from Qualys, Inc. The Scanner Appliance offers QualysGuard users the ability to extend their use of the service to assess the security of internal network systems, devices and web applications.

The QualysGuard Scanner Appliance is packaged as a network appliance, pre-installed with Scanner Appliance software, and pre-configured for ease of installation and deployment within the enterprise.

Note: Your use of the QualysGuard Scanner Appliance is subject to the terms and conditions of the QualysGuard Service User Agreement.

About Qualys

Qualys, Inc. is the leading provider of Software-as-a-Service (SaaS) IT security risk and compliance management solutions. Qualys solutions are deployed in a matter of hours anywhere in the world, providing customers an immediate and continuous view of their security and compliance postures.

Qualys is headquartered in Redwood Shores, California with regional offices worldwide. For more information about Qualys, please visit www.qualys.com.

Contact Qualys Support

Qualys is committed to providing you with the most thorough support. Through online documentation, telephone help, and direct email support, Qualys ensures that your questions will be answered in the fastest time possible. We support you 7 days a week, 24 hours a day. Access support information at www.qualys.com/support/.



CHAPTER 1

Scanner Appliance Installation

Welcome to the QualysGuard® Scanner Appliance, an option with the QualysGuard service from Qualys, Inc. Delivered on demand, the QualysGuard IT Security and Compliance Suite automates vulnerability management and policy compliance, ensuring the security of information networks. With the QualysGuard Scanner Appliance, you can assess internal network devices, systems and web applications.

The Scanner Appliance is a robust, scalable solution for scanning large, distributed networks.

This chapter introduces you to the Scanner Appliance and includes an easy to follow Quick Start for completing the installation. These topics are covered:

- Before You Begin
- Quick Start
 - Step 1 — Connect the Scanner Appliance to the Network
 - Step 2 — Power On the Scanner Appliance
 - Step 3 — Activate the Scanner Appliance
- Qualys Secure Global Architecture
- Scanning and Firewalls
- What's Next

Important! The software version installed on your Scanner Appliance determines the Quick Start steps and whether certain features are available. After installation, the **VERSION INFO** screen displays the software version number currently running on the appliance.



Before You Begin

Please review the sections below before using the Scanner Appliance for the first time.

Package Accessories

Your starter kit package should contain these components:

- *QualysGuard Scanner Appliance User Guide*
- AC power cord
- CAT 5 cable
- 19" rack mount bracket kit including: left-side mounting bracket, right-side mounting bracket, 10-32 x 3/4" black rack screws (4), 10-32 x 5/16" stainless steel screws (6)
- Adhesive round bumpers (4) for desk mount
- USB-to-RS232 converter cable when the Scanner Appliance is shipped with software version 2.4 (or later) installed; see "Remote Console Interface Set Up (Version 2.4 or later)"

If any components are missing or damaged, please contact Qualys Support.

Rack Mount Instructions

To rack mount the Scanner Appliance, follow these steps:

- 1 With a #2 flat blade screwdriver, remove all 6 plastic screws on both sides of the scanner (3 on Right side, and 3 on Left side).
- 2 Align the Right mounting bracket to Right side of the scanner. With a #2 Philips screwdriver, attach the bracket to the scanner chassis using 3 10-32 x 5/16" stainless steel screws.
- 3 Align the Left mounting bracket to the Left side of the scanner. With a #2 Philips screwdriver, attach the bracket to the scanner chassis using the remaining 3 10-32 x 5/16" stainless steel screws.
- 4 Use 4 10-32 x 3/4" rack screws to mount the scanner onto the rack chassis.

Rack mount safety notes are provided in Appendix C, "Safety Notices."

Managed Power Supply

Qualys strongly recommends the Scanner Appliance be plugged into a Managed Power Supply. On the rare occasion where the Scanner Appliance may need to be rebooted, utilizing the MPS will allow for remote rebooting in unmanned or high security areas.

Review Network Requirements

The Scanner Appliance has the following network requirements.

Outbound HTTPS Access	The local network must be configured to allow outbound HTTPS (port 443) access to the Internet, so that the Scanner Appliance can communicate with the QualysGuard platform.
Accessibility of Target IP Addresses	The IP addresses for the hosts to be scanned must be accessible to the Scanner Appliance. This is particularly important if your network is designed with VLANs.
Bandwidth	Minimum recommended bandwidth connection of 1.5 megabits per second (Mbps) to the QualysGuard platform.
DHCP or Static IP	By default the Scanner Appliance is pre-configured with DHCP. If configured with a static IP address, be sure you have the IP address, netmask, default gateway, and primary DNS.
Proxy Support	The Scanner Appliance includes Proxy support with or without authentication — Basic or NTLM. The Proxy server must be assigned a static IP address and must allow transparent SSL tunneling. Proxy-level termination (as implemented in SSL bridging, for example) is not supported.

Scanning and Firewalls

Executing a scan or map against a device shielded by a firewall is a common operation. Every day the Qualys scanning engine executes thousands of scans in network topologies that protect their servers with firewalls without any issues. Problems can arise when the scan traffic is routed through the firewall from the inside out, i.e. when the Scanner Appliance is sitting in the protected network area and scans a target which is located on the other side of the firewall. Many modern firewalls are configured to track connections, maintain NAT and ARP tables and a scan operation against a large set of targets can overload these tables. The consequences of such overflows are varied and range from slowdown of the firewall functions to a complete crash.

We recommend placing Scanner Appliances in your network topology in a way that scanning and mapping through a firewall from the inside out is avoided if possible. If not, we recommend you perform your own assessment testing on your network to validate the impact to your firewall. The accuracy of your scan may also be impacted so you should compare expected results against the detailed results provided in your QualysGuard reports. It's possible this can be service impacting as the scan results might differ.

Network Traffic Options

The Scanner Appliance traffic connections are established from the Scanner Appliance to the QualysGuard platform over HTTPS port 443 and secured with SSL. There are two network traffic configurations: Standard and Split.

In the Standard network configuration, which is enabled by default, the LAN connector services both scanning traffic and management traffic to the QualysGuard platform.

In the Split network configuration, the Scanner Appliance separates scanning traffic and management traffic, using both the LAN and WAN connectors. No internal traffic is routed or bridged to the WAN port, and no management traffic is routed or bridged to the LAN port.

The Scanner Appliance implements logical separation of scanning traffic and management traffic, regardless of which configuration option is used. Management traffic includes updates to software and vulnerability signatures, ensuring the overall health of the appliance, as well as data related to processing security audits.

Physical Requirements

The physical requirements for the Scanner Appliance are described below.

Requirement	Description
Size	1 U height – 1.7" x 14.25" x 9.39"
Power	100 to 240 V~, 50 to 60 Hz, 4 A
Weight	8.5 lbs.
Operating environment	0 to 35 C at sea level, 10 to 85% R.H. (non-condensing)
Storage environment	-20C to 70 C, 10 to 85% R.H. (non-condensing)

QualysGuard Account

You will need a QualysGuard user account to install the appliance following the instructions in the Quick Start. A user account with any role except Contact may be used. When your user account is first created, you will receive an email notification with a secure link to your new login credentials. Check to be sure that you have your account information. Please contact Qualys Support or your Qualys account representative if you need assistance.

IMPORTANT NOTICE

Qualys makes a significant effort to perform security audits in a nondestructive and non-intrusive fashion. However, under certain circumstances, such as when systems have not been kept up to date for some period of time, these systems may be impacted. In particular, services or systems may stop responding, and may require restart or reboot.

Quick Start

This Quick Start describes how to set up and configure the Scanner Appliance so that you can start using the Scanner Appliance with the QualysGuard service right away. There are three basic steps involved. It is important that you complete the Quick Start steps in the order described.

Once you have completed the Quick Start sequence, you can start launching scans. Vulnerability scanning is available for all subscriptions. Your account may allow compliance scanning and web application scanning. The Scanner Appliance keeps itself updated with the latest vulnerability signatures and compliance controls via its connection to the QualysGuard platform.

Step 1 — Connect the Scanner Appliance to the Network

Set Up Network Connection

The Scanner Appliance connects like any other computer to a switch on your network.

To set up the network connection, follow these steps:

- Connect one end of an Ethernet cable to the Ethernet LAN port on the Scanner Appliance (back panel).
- Connect the other end of the Ethernet cable to a 10BASE-T or 100BASE-TX or 1 Gigabit switch on your network.

Remote Console Interface Set Up (Version 2.4 or later)

The Remote Console interface feature is available when the Scanner Appliance is running software version 2.4 (or later).

The Remote Console interface supports remote configuration and management of the Scanner Appliance using a VT100 terminal, such as Windows HyperTerminal.

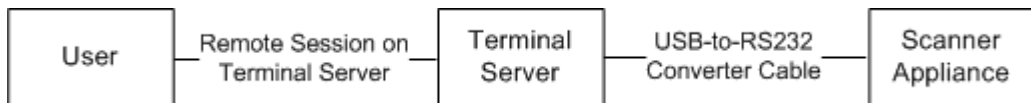

Figure 1-1. Set up for Remote Console Interface

A Scanner Appliance shipped with software version 2.4 (or later) includes a USB-to-RS232 converter cable for the customer to connect to their terminal server via network cable.

Qualys recommends the following USB-to-RS232 converter cable:

IOGEAR USB-Serial Model GUC232A

Full specifications: <http://www.iogear.com/product/GUC232A/>

To set up the Remote Console interface, follow these steps:

- 1 Be sure the terminal server is up and running. Also check the terminal server settings. The following settings are required.

Port Setting	Value
Bits per second (Baud rate)	9600
Data Bits	8
Parity	None
Stop Bits	2
Flow Control	None
Terminal Emulation	VT100

- 2 Connect one end of the USB-to-RS232 converter cable to a USB port on the Scanner Appliance (back panel).
- 3 Connect the other end of the USB-to-RS232 converter cable to your terminal server via network cable.
- 4 Connect the Scanner Appliance as described in “Step 2 — Power On the Scanner Appliance.”

Note: In the case where the Scanner Appliance is already powered on when you connect the USB-to-RS232 converter cable to the Scanner Appliance, you must reboot the Scanner Appliance before taking the next step and making any configurations. To reboot, press the Down arrow on the LCD interface until the **SYSTEM REBOOT** message appears and then press ENTER. Please make sure that the Scanner Appliance has fully rebooted (this takes up to 3 minutes).

- 5 Press the ENTER key on the VT100 terminal’s keyboard to display the Remote Console interface.

You will notice the MAC address for the Scanner Appliance appears. The menus and messages are identical to those in the LCD interface. Once the Quick Start has been completed, the Scanner Appliance friendly name and IP address appears on every screen.

Keystroke File Not Supported: The Remote Console interface is not intended for uploading the whole scanner configuration by means of a pre-defined “keystroke file.” Uploading such a file will result in lost characters and incorrect configuration.

Step 2 — Power On the Scanner Appliance

To power on the Scanner Appliance, follow these steps:

- 1 Connect the AC power cord into the Power Supply Socket.

Note: Qualys strongly recommends the Scanner Appliance be plugged into a Managed Power Supply. On the rare occasion where the Scanner Appliance may need to be rebooted, utilizing the MPS will allow for remote rebooting in unmanned or high security areas.

- 2 Check to be sure that the amber PWR LED is lit.

- 3 **Welcome to QualysGuard** appears in the Scanner Appliance interface followed by other informational messages during the boot process which takes approximately two minutes. These messages appear in the order shown:

```
Welcome to QualysGuard
Qualys Scanner is starting up...
Filesystem check in progress...
Qualys Scanner is coming up...
```

- 4 Check the message indicating the activation status of the Scanner Appliance. One of these messages appears when the Scanner Appliance made a successful connection to the QualysGuard platform:

- **SA LOGIN** — The Scanner Appliance is running software version 2.2. Go to “Step 3 — Activate the Scanner Appliance” for instructions.
- **ACTIVATION CODE** — The Scanner Appliance is running software version 2.4 or later. The activation code for the Scanner Appliance is displayed. A unique code is assigned to each appliance. Make a note of the activation code and then go to “Enter the Activation Code (Version 2.4 or later)” for instructions.

One of these messages appears when the Scanner Appliance did not make a successful connection to the QualysGuard platform:

- **ACTIVATION CODE/NETWORK ERR.** — The service determined the appliance is running software version 2.4 or later, and the appliance has not been activated yet. The network error must be resolved before you go to Step 3.
- **NETWORK ERROR** — Press ENTER to return to the **SETUP NETWORK** menu option. You may need to enable additional configurations so that the Scanner Appliance can connect to the QualysGuard platform. The network error must be resolved before you go to Step 3.

Note: If the Remote Console will be used, it may be necessary to press the ENTER key on the VT100 terminal’s keyboard to display the Remote Console interface.

Complete the Network Configuration

Enable the network configurations for the Scanner Appliance, as appropriate, in the order listed. One or more configurations may be required. Any network error must be resolved before going to Step 3. Please refer to Appendix B for help with resolving errors.

Configuration Options	For information ...
A Static IP Address	See "Static IP Address Configuration" on page 47
B Proxy Support	See "Proxy Configuration" on page 51
C Split Network Configuration using DHCP	See "Enable the WAN Interface" on page 57 and "Enable DHCP on the WAN Interface" on page 58
D Split Network Configuration using a Static IP Address	See "Enable the WAN Interface" on page 57 and "Enable Static IP on the WAN Interface" on page 58

Use the options chart below to determine the configurations needed.

	DHCP w/o Proxy	Static IP w/o Proxy	DHCP with Proxy	Static IP with Proxy
Standard Config	no action	A	B	A & B
Split Netw. Config: DHCP on WAN	C	A & C	B & C	A, B, & C
Split Netw. Config: Static IP on WAN	D	A & D	B & D	A, B, & D

The Scanner Appliance supports VLAN interface configuration (802.1Q). For information, see "VLAN Interface Configuration" on page 45.

You may see the **NETWORK ERROR** message one or two more times, depending on how many configurations are needed. For example, if the Scanner Appliance is installed on a network with DHCP and a Proxy server, and you want split network configuration with DHCP, you enable options B and C. After you enable option B, **NETWORK ERROR** appears prompting you to make another configuration.

Step 3 — Activate the Scanner Appliance

Important! The software version installed on your Scanner Appliance determines the activation method to be used. There are different activation methods for software version 2.2 and 2.4 (or later).

Log into the Scanner Appliance (Version 2.2)

When software version 2.2 is installed on the Scanner Appliance, you activate the Scanner Appliance by logging into the QualysGuard web application first and then logging into the Scanner Appliance following the instructions below. The account used must be defined for use with the Scanner Appliance.

Log into the QualysGuard Web Application First

To log into the Scanner Appliance, follow these steps:

- 1 Open a browser and go to the platform URL where your QualysGuard account is located. Please refer to your registration email containing your platform URL and login credentials. A user account with any user role may be used.
- 2 On the QualysGuard **LOGIN** page, enter your user name (login) and password, and then click **LOGIN**. You are prompted to review and accept the licensing agreement when you log into your account for the first time. Your QualysGuard Home page appears upon successful login.

Log into the QualysGuard Scanner Appliance

To log into the QualysGuard Scanner Appliance, follow these steps:

- 1 The **SA LOGIN** prompt appears after you powered on the Scanner Appliance in Step 1. Press ENTER.
- 2 At the **SA USER** prompt, enter your QualysGuard user name using the LCD keypad. See “Using the LCD Keypad” below. Press ENTER.
- 3 At the **SA PASSWD** prompt, enter your QualysGuard password using the LCD keypad. Press ENTER.

Using the LCD Keypad

Initially, the user and password fields are filled with space characters, and the cursor is in the first character position. Use the arrow buttons to move the cursor and make entries.

Scroll Up — Use the Up arrow to scroll up through characters in this order: lowercase letters (a through z), space, numbers (0 through 9), special characters, underscore, uppercase letters (A through Z).

Scroll Down — Use the Down arrow to scroll down through characters in reverse order: uppercase letters (Z through A), underscore, special characters, numbers (9 through 0), space, lowercase letters (z through a).

Move to the Left — Use the Left arrow to move the cursor to the left in the field.

Move to the Right — Use the Right arrow to move the cursor to the right in the field.

For more information, see “Menus and Navigation” in Chapter 3, “Scanner Appliance Tour.”

- 4 The Scanner Appliance attempts the login to the QualysGuard platform. This might take a minute or two, depending on network traffic.
- 5 The **SCANNER APPLIANCE NAME-IP ADDRESS** message appears after the Scanner Appliance makes a successful login to the QualysGuard platform. If another message appears, see Appendix B, “Troubleshooting,” for help with troubleshooting this issue.

Enter the Activation Code (Version 2.4 or later)

When software version 2.4 (or later) is installed on the Scanner Appliance, you activate the Scanner Appliance using an activation code. This code is unique to your Scanner Appliance and displayed automatically after you complete Step 2.

To activate the Scanner Appliance, follow these steps:

- 1 Open a browser and go to the platform URL where your account is located. Please refer to your registration email containing your platform URL and login credentials. A Manager or Unit Manager account is required.
- 2 On the QualysGuard **LOGIN** page, enter your user name (login) and password, and then click **LOGIN**. You are prompted to review and accept the licensing agreement when you log into your account for the first time. Your QualysGuard Home page appears upon successful login.
- 3 Using the new user interface, select VM from the application picker.
- 4 Go to Scans > Appliances.
- 5 Select New > Scanner Appliance and enter the activation code for the activation code appears in the **ACTIVATION CODE** screen in your appliance's user interface (LCD and Remote Console). Note: The activation code is displayed only when the appliance has not been activated yet.
- 6 Unit Manager only) From the Add To menu, select an asset group that you want to add the Scanner Appliance to. This will make the appliance available to users in your business unit.
- 7 Click Activate.

The Scanner Appliance attempts the login to the QualysGuard platform.

Note: It may take a few minutes for the Scanner Appliance activation to occur. If you prefer not to wait, complete the activation manually by restarting the Scanner Appliance. To do this, press the Down arrow until the **SYSTEM REBOOT** screen appears and then press ENTER. When the **REALLY REBOOT SYSTEM?** screen appears press ENTER.

- 8 The **SCANNER APPLIANCE NAME-IP ADDRESS** message appears after the Scanner Appliance makes a successful login to the QualysGuard platform. If another message appears, see Appendix B, "Troubleshooting," for help with troubleshooting this issue.

Quick Start Complete

When the Scanner Appliance name and IP address for your Scanner Appliance appear in the interface (LCD or Remote Console), this indicates you have completed the Quick Start, the Scanner Appliance has been added to your subscription.

Tip: Before you launch scans using the Scanner Appliance, we recommend you log into the QualysGuard user interface and check the appliance status. See “Check Scanner Appliance Status” in Chapter 2 for information.

Scanner Appliance Name and IP Address

The Scanner Appliance name and IP address appear as shown below.



The Scanner Appliance name displayed is “is_Username”, where *username* is your QualysGuard user name. The name can be changed using the QualysGuard user interface, as described in “Edit Scanner Appliance Settings” in Chapter 2.

The IP address is available for information purposes only. The Scanner Appliance is remote controlled by the QualysGuard platform, and the appliance does not allow incoming logins or connections from the network. If split network configuration is enabled, the IP address for the LAN interface is displayed.

The QualysGuard platform indicator for your account appears in the lower right corner.

Proper System Shutdown

It is important to shut down the system properly. If you do not follow the shutdown procedure described below, file system corruption may occur. There is a **SYSTEM SHUTDOWN** option for shutting down the system from the Scanner Appliance interface. Use the arrow keys to display this menu option and then press ENTER. When the **REALLY SHUT DOWN SYSTEM?** screen appears press ENTER.

Important! The Scanner Appliance should now power down within 60 seconds. When this message appears: “It’s now safe to unplug the box”, then you can safely unplug the Scanner Appliance.

Qualys Secure Global Architecture

QualysGuard provides end to end security, connecting QualysGuard Security Operations Centers (SOCs) to remote intranet scanners, Scanner Appliances and users. When Managers add new users and assign roles to them, QualysGuard uses the role-based permissions to grant users access to scan data (manage, scan, or read only).

The components of the Qualys Global Web Service Architecture are described below.

Web User Interface. The Web User Interface provides secure access to QualysGuard at any time, from anywhere.

Security Operations Centers (SOCs). Qualys SOCs provide secure storage and processing of vulnerability data on an n-tiered architecture of load-balanced application servers. High availability, continuously monitored, safe datacenters host physically and logically secure databases with encrypted data storage.

Internet Remote Scanners. QualysGuard's Internet Scanners provide fast and efficient external scanning. Qualys hosts a collection of Internet Scanners optimized to scan publicly facing devices globally via the Internet. The inference-based scanning engine employs an un-trusted approach for greater accuracy in results and scalable performance.

Scanner Appliances. QualysGuard Scanner Appliances are appliance versions of the Internet Remote Scanners, which enable customers to bring QualysGuard's assessment capabilities to their internal networks. The appliance needs no special firewall configurations to obtain updates including new vulnerability signatures and to perform scan jobs, returning results securely over a standard SSL-encrypted channel.

QualysGuard Data Security. The QualysGuard web service is the first and only solution to encrypt vulnerability data end-to-end, ensuring the data is secure at any time so only customers have access to the scan data. VeriSign® Identity Protection (VIP) is available to customers seeking two-factor authentication.

QualysGuard's data security has undergone an SAS-70 audit and a comprehensive penetration test from trusted third parties confirming the security of the architecture.

What's Next

You are ready to use QualysGuard! Now you can start using your QualysGuard Scanner Appliance to run scans on assets within your internal network, view scan results, generate reports, remediate vulnerabilities and achieve compliance.

Chapter 2, "Set Up Using QualysGuard," describes how to check the Scanner Appliance status and make configuration settings to change the appliance name and polling interval and grant access to additional users.

Chapter 3, "Scanner Appliance Tour," describes the Scanner Appliance configuration options available using the LCD interface and Remote Console interface.

Appendix A, "Interface Maps," provides a map of the Scanner Appliance interface messages and prompts for the most recent software versions.

Appendix B, "Troubleshooting," provides techniques for troubleshooting common problems with setting up and running the Scanner Appliance. Corrective responses to error messages are given.

Appendix C, "Safety Notices," lists safety notices for the QualysGuard Scanner Appliance.

Appendix D, "Credits," lists software credits for the QualysGuard Scanner Appliance.

Set Up Using QualysGuard

This chapter describes how to use the QualysGuard user interface to check the status of your Scanner Appliance and to make configuration settings to support scanning within your enterprise.

Using QualysGuard you can take these actions on a newly installed appliance:

- Check Scanner Appliance Status (recommended)
- Edit Scanner Appliance Settings
- Grant Users Access to a Scanner Appliance
- Replace Scanner Appliance





Check Scanner Appliance Status

It's recommended you check the New Scanner Services status before launching scans using a newly installed Scanner Appliance.

The New Scanner Services status identifies whether the Scanner Appliance has connectivity to New Scanner Services at the SOC (Security Operations Center). New Scanner Services is a part of our global scanning infrastructure.

How to check the New Scanner Services status:

- 1 Using the new UI, go to Scans > Appliances. (Using the original UI, select Scanner Appliances under Tools.)
- 2 From the scanner appliances list, identify the Scanner Appliance you want to check the status for.
- 3 Check the New Scanner Services indicator in the  column. When the status is  (Connected) or  (Not Used) the Scanner Appliance is ready to process new scans. See below for details on the status indicators. (Managers and Unit Managers can click Check Now in the appliance's preview pane to request the most recent status.)

New Scanner Services Status

 (Connected) status shown in the new UI:

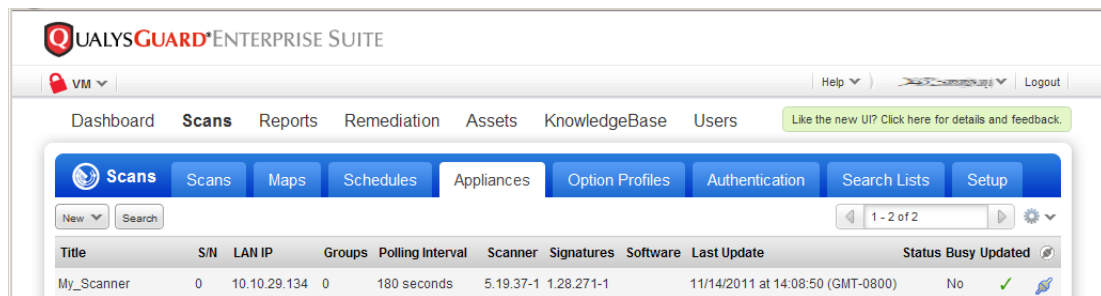

 (Connected) status shown in the original UI:

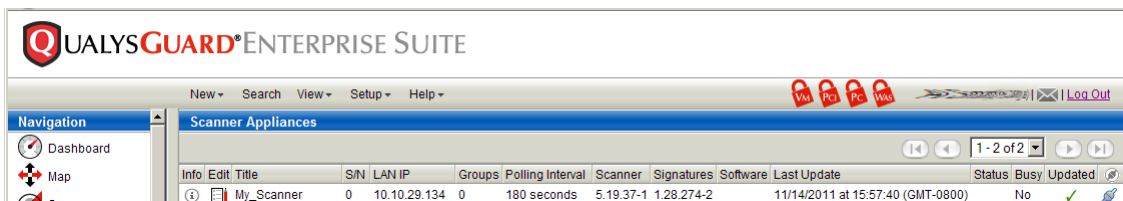

When the status is  (Not Connected) the Scanner Appliance is not ready to process new scans. We recommend you check to be sure the appliance has network access to the scanning servers at the Security Operations Center (SOC). Appliances installed in your network must be able to send probes to target hosts from these URLs and you may need to whitelist them. Go to Help > About to see the list of scanning server URLs for your account. Please contact support if you need help troubleshooting this issue.

Notice to Customers: We are in the process of transitioning customers to use New Scanner Services. During the transition period, your subscription may not be configured to use New Scanner Services. If your account has not been configured yet, the status  (Not Used) appears, and this is no reason for concern. The appliance is ready for scanning. To see whether your subscription has been configured (enabled) for New Scanner Services, go to Help > Account Info > General Information.

Additional Status

Additional status indicators are provided for your information.

Status — For the heartbeat status, a newly installed Scanner Appliance should be online (blank). This means the appliance passed the latest heartbeat check performed by the service. The heartbeat check status is offline (yellow warning icon) if the appliance failed the most recent heartbeat check. A heartbeat check is performed every 4 hours.

Busy — A newly installed Scanner Appliance will not be busy until a user launches a scan using the appliance. The status Yes indicates the scanner is busy running one or more scans and/or maps.

Updated — The software is up to date when  (green check) appears. After your Scanner Appliance has been installed the software should be up to date. The service will automatically update the software so you do not need to take any action to get software updates. You have the option to request a manual update by editing the Scanner Appliance. See “Edit Scanner Appliance Settings” for information.

Edit Scanner Appliance Settings

Scanner Appliance settings may be customized using QualysGuard. Users with management privileges (Managers and Unit Managers) have the ability to edit a Scanner Appliance.

From the New UI, go to Scans > Appliances. Identify the Scanner Appliance you want to edit and click anywhere in the data list row to see the Quick Actions menu. Select Edit from the Quick Actions menu. The Edit Scanner Appliance page appears.

The screenshot shows the 'Edit Scanner Appliance' interface in the New UI. It features a blue header bar with the title 'Edit Scanner Appliance' and a 'Launch Help' link with a close icon. A left-hand navigation pane lists several categories: 'General Information' (which is currently selected and highlighted in blue), 'Scanner Options', 'Versions', 'VLANs', 'Static Routes', and 'Comments'. The main content area is titled 'General Information' and contains a 'Reboot' button at the top left. Below this, there are several configuration fields: 'Scanner Appliance: *' with the value 'is_scand_sd9', 'User Login: scand_sd', 'Type: Physical Scanner', 'Serial Number: 1001', and 'Polling Interval: *' with the value '80'. The 'Notification:' section includes a checked checkbox for 'Email status if scanner appliance misses' and a dropdown menu set to '5 heartbeat checks (4 hour intervals)'. At the bottom of the main area are 'Cancel' and 'Save' buttons.

From the original UI, select Scanner Appliances on the left menu, under Tools. Identify the Scanner Appliance you want to edit and select the Edit icon. The Edit Scanner Appliance page appears. (Scanner Appliance settings are described on the next page.)

The screenshot shows the 'Edit Scanner Appliance' interface in the original UI. It has a grey header bar with the title 'Edit Scanner Appliance'. The main content area is titled 'General Information' and contains a 'Reboot' button at the top right. Below this, there are several configuration fields: 'Scanner Appliance: *' with the value 'is_scand_sd9', 'User Login: scand_sd', 'Type: Physical Scanner', 'Serial Number: 1001', and 'Polling Interval: *' with the value '80'. The 'Notification:' section includes a checked checkbox for 'Email status if scanner appliance misses' and a dropdown menu set to '5 heartbeat checks (4 hour intervals)'. Below the main content area are tabs for 'Scanner Options', 'Versions', 'VLANs', and 'Static Routes'. The 'Scanner Options' tab is selected, showing an 'FDCC' section with the text 'Enable FDCC on this appliance.' and a checkbox for 'Enable FDCC'.

Scanner Appliance Settings

Scanner Appliance settings include:

Scanner Appliance (name) — The friendly name for the Scanner Appliance. This appears in the QualysGuard user interface and the Scanner Appliance user interface (LCD display and Remote Console).

Polling Interval — The polling interval identifies how often the Scanner Appliance polls the QualysGuard platform for new information, including configuration updates and user requests for scans. The initial polling interval is set to 180 seconds (3 minutes). The polling interval can be set to 60 to 3600 seconds.

Notification — Select this option to send a heartbeat check notification to users when the Scanner Appliance fails to make a connection to the QualysGuard platform after a number of attempts (1 to 5). Each user has the option to enable this notification in their own account.

Reboot — Click the Reboot button to reboot the Scanner Appliance if necessary. **Important:** While rebooting a Scanner Appliance may be necessary at times, taking this action can impact our ability to troubleshoot and track down an underlying issue with the Scanner Appliance, such as its network configuration. Please contact Support if there is a need to reboot a Scanner Appliance multiple times or on a continuous basis.

It's possible to reboot the Scanner Appliance using the Scanner Appliance interface (LCD and Remote Console). See “System Reboot and Shutdown” in Chapter 3.

Versions — Go to the Versions section to check the versions for the Scanner Appliance components currently installed on the appliance. If out of date, you have the option to click the “Update Now” button to request an update manually. Depending on your network load and download file sizes, the time it takes to update the software will vary.

VLANs and Static Routes — Go to the VLANs and Static Routes sections to set these optional configurations. Please refer to the online help for complete information.

When Updated Scanner Appliance Settings Take Effect

After you edit Scanner Appliance settings, changes take effect the next time the Scanner Appliance contacts the QualysGuard platform. If you configured the Scanner Appliance with Proxy support, you may notice a lag time before the changes take effect. This can be significantly longer than the polling interval because there is additional time necessary for communications through the Proxy server.

You'll notice when an automatic software update is in progress, the S2 LED on the Scanner Appliance front panel is lit. It is recommended to wait until the S2 LED light is off, when it is safe to run scans.

Grant Users Access to a Scanner Appliance

Upon completion of the Quick Start, the Scanner Appliance is installed in the subscription account. Manager users are granted access to the Scanner Appliance automatically.

Other users (Unit Managers, Scanners, Readers) are not granted access to a newly installed Scanner Appliance without authorization. Initially, these users do not view the Scanner Appliance when logged into their accounts and they cannot launch scans using the appliance.

Note: It's possible to install a Scanner Appliance using a QualysGuard user account that has any user role. Regardless of the account used, the service initially makes the Scanner Appliance available only to Managers.

To grant users access to a Scanner Appliance, a Manager must add the Scanner Appliance to one or more asset groups and then grant users access to these asset groups. For Scanners and Readers not assigned to a business unit, a Manager edits each user account and adds the asset groups to each user's Assigned Asset Groups list. For a Unit Manager, a Manager adds the asset groups to the business unit that the Unit Manager belongs to. Following that, any Manager or Unit Manager of the same business unit may grant access to other users (Scanners, Readers) in the business unit. Once granted access, users will view the appliance in their scanner appliances list and can use the appliance based on user role-based privileges.

For a subscription with multiple Scanner Appliances and business units, it's recommended best practice that Managers create a master asset group for each business unit, where each master asset group contains all Scanner Appliances, IPs and domains for the business unit. Next, Managers create business units by adding a master asset group to each unit. Following that, Unit Managers have the ability to manage the Scanner Appliances for their assigned business unit and grant other users in the same business unit (Scanners and Readers) access to these appliances, as appropriate.

Replace Scanner Appliance

The Replace Scanner Appliance workflow allows easy replacement of Scanner Appliances and their settings. This workflow for replacing a Scanner Appliance performs bulk migration of all scanner settings to the new appliance. It can be accessed by going to Scanner Appliances, under Tools, and then selecting New > Replace Scanner Appliance.

Use the new Replace Scanner Appliance workflow to quickly replace a Scanner Appliance in your account with a new Scanner Appliance. This workflow is available to Managers and Unit Managers. Managers have the ability to replace any Scanner Appliance in the subscription. Unit Managers have the ability to replace any Scanner Appliance assigned to their business unit.

Before You Begin

Install a new Scanner Appliance following the 3-step Quick Start included in the QualysGuard Scanner Appliance User Guide (Help > Resources > Scanner Appliance).

It's recommended that you do not replace a Scanner Appliance while scans are in progress. Running and paused/resumed scans will not be updated to use the new Scanner Appliance. The service will attempt to complete these scans using the old Scanner Appliance.

Select the Replace Option

From the new UI, go to Scans > Appliances. Then select New > Replace Scanner Appliance.

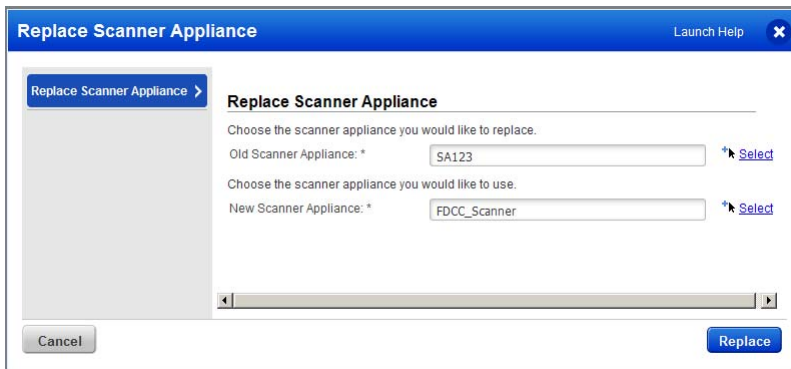

The screenshot shows a dialog box titled "Replace Scanner Appliance" with a "Launch Help" button in the top right corner. On the left side, there is a button labeled "Replace Scanner Appliance" with a right-pointing arrow. The main content area is titled "Replace Scanner Appliance" and contains two sections:

- The first section is titled "Choose the scanner appliance you would like to replace." and contains a text input field labeled "Old Scanner Appliance: *" with the value "SA123" and a blue "Select" button with a magnifying glass icon.
- The second section is titled "Choose the scanner appliance you would like to use." and contains a text input field labeled "New Scanner Appliance: *" with the value "FDCC_Scanner" and a blue "Select" button with a magnifying glass icon.

At the bottom of the dialog box, there are two buttons: a grey "Cancel" button on the left and a blue "Replace" button on the right.

From the original UI, select Scanner Appliances on the left menu, under Tools. Then select New > Replace Scanner Appliance.

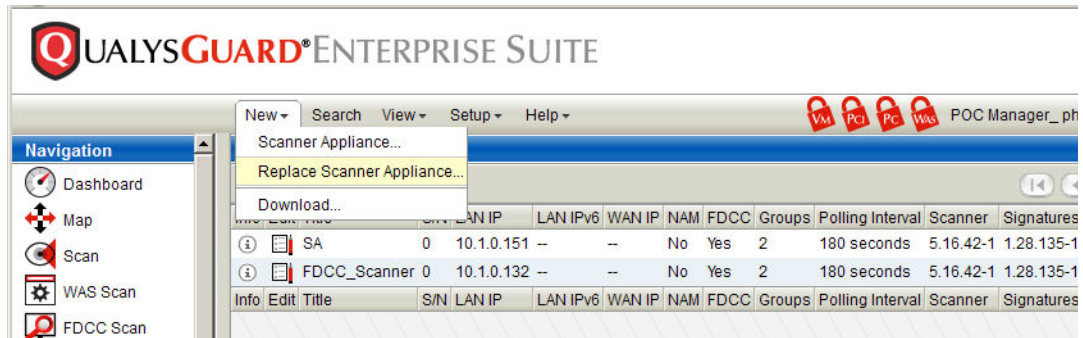

Complete the Replace Workflow

- 4 Choose the old and new Scanner Appliance. Then click the Replace button.
- 5 Review the Warning message and then click the View Report button.
- 6 Review the Replace Scanner Appliance Report. The report identifies:
 - a) Which appliance settings will be copied from the old appliance to the new one
 - b) Which asset groups and scheduled tasks, if any, will be updated to use the new appliance (if these configurations include the old appliance prior to replacement)
 - c) Which asset groups and scheduled tasks, if any, will be updated to remove the new appliance (if these configurations include the new appliance prior to replacement)
- 7 Close the report and click the REplace button under the warning message.

How it Works

When you replace a Scanner Appliance, the following appliance settings will be updated:

- These scanner appliance settings will be copied from the old appliance to the new appliance: polling interval, heartbeat checks setting, FDCC setting (enabled or disabled), VLAN configurations and Static Route configurations.
- The new Scanner Appliance will replace the old appliance in the old appliance's asset groups and scheduled tasks.
- If the new Scanner Appliance is defined in asset groups and scheduled, the new appliance will be removed from these configurations.

Scanner Appliance Tour

This chapter provides a tour of the QualysGuard Scanner Appliance, its features, basic operation and configuration options.

Important! The software version installed on your Scanner Appliance determines whether certain features are available. The **VERSION INFO** screen displays the software version number currently running on the appliance. See “Menus and Navigation” for information.

This chapter covers these topics:

- Becoming Familiar with the Appliance
- About the LCD Display
- About the Remote Console Interface
- Menus and Navigation
- System Reboot and Shutdown
- Qualys User/Password Store (Version 2.2)
- VLAN Interface Configuration
- Static IP Address Configuration
- Proxy Configuration
- Split Network Configuration
- Reset the Network Configuration
- Changing the Network Configuration



Becoming Familiar with the Appliance

The next few sections introduce you to the Scanner Appliance.



Figure 3-1. QualysGuard Scanner Appliance

User Interface

The Scanner Appliance includes a user interface for configuration and management. Users may choose to use the LCD display and keypad or the optional Remote Console interface for remote access via a VT100 terminal, such as Windows HyperTerminal. The Remote Console option is available when Scanner Appliance software version 2.4 or later is installed. Both the LCD display and Remote Console offer the same functionality and share the same menus and navigation (ENTER key and arrows) for a consistent user experience.

See Chapter 3, “Scanner Appliance Tour” for information on using the Scanner Appliance user interface.

Front Panel

The front panel includes LED indicators, as well as an LCD display and keypad.

LCD Display

The LCD display and keypad, on the right of the Qualys logo, are used to log into the Scanner Appliance, enter network configuration settings, and perform system operations.

Messages and prompts appear in the LCD display. When you connect the appliance to the network for the first time, the **Welcome to QualysGuard** message appears. After you complete the Quick Start, the Scanner Appliance identification information appears — the Scanner Appliance name and IP address.

The keypad to the right of the LCD display allows you to enter information and respond to prompts. The keypad includes four arrow buttons and the ENTER button.

- The Left and Right arrow buttons move the cursor to the left and right in an entry field.
- The Up and Down arrow buttons scroll through menu options, and scroll through characters in an entry field.
- The ENTER button, in the center, is used to confirm entries and move to the next screen.

LED Indicators

The LED indicators appear on the left side of the front panel.

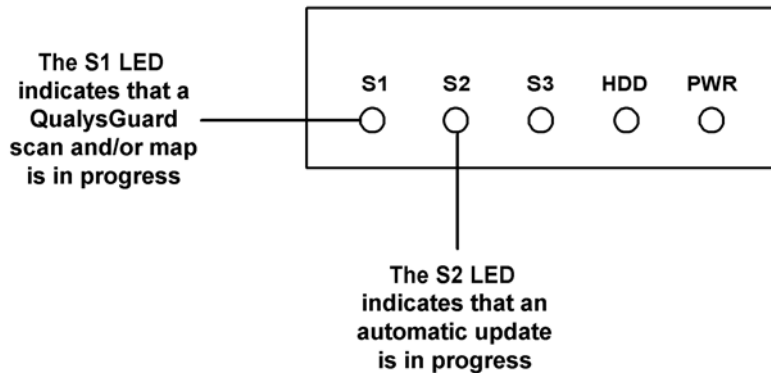

Figure 3-2. LEDs on the Appliance Front Panel

LED Label	Description
S1	The S1 LED indicates that a QualysGuard scan and/or map is in progress on the Scanner Appliance.
S2	The S2 LED indicates that an automatic update to the Scanner Appliance software is in progress.
S3	The S3 LED is not used.
HDD	The HDD LED indicates that there is activity on the internal hard drive.
PWR	The PWR LED indicates that power is supplied to the unit, and the appliance is turned on.

Back Panel

The appliance's back panel includes these connectors: the power socket, the Ethernet LAN port, the Ethernet WAN port, and two USB ports.



Figure 3-3. Appliance Back Panel

Power Socket — The power socket is used to connect the power connector to the appliance. The power socket is located on the right side of the back panel.

Ethernet LAN Port — A connection to the Ethernet LAN port is required. The Ethernet LAN port is located in the middle of the back panel. The LAN port connects the appliance to a hub or switch on your network using a straight through CAT5 twisted pair Ethernet cable.

Ethernet WAN Port — A connection to the Ethernet WAN port is required only if you elect to use the split network configuration option. The Ethernet WAN port is located in the middle of the back panel. The WAN port connects the appliance to a hub or switch on your network using a straight through CAT5 twisted pair Ethernet cable.

USB Ports — The two USB ports are not functional when the Scanner Appliance is running software version 2.2. When the Scanner Appliance is running software version 2.4 (or later) the Remote Console interface may be configured using a USB port (either port may be used).

About the LCD Display

The first time you power up the Scanner Appliance, the **Welcome to QualysGuard** message appears in the LCD screen followed by other startup messages. The Scanner Appliance name and IP address appear after you complete the Quick Start. Menu options allow you to shut down the system, reboot the system and make configuration settings.



Figure 3-1. Scanner Appliance Front Panel and LCD Display

About the Remote Console Interface

The Remote Console interface is available only when the Scanner Appliance is running software version 2.4 (or later). You have the option to use the Remote Console interface for managing the Scanner Appliance instead of using the LCD display. The same menu options that appear in the LCD display also appear in the Remote Console interface.

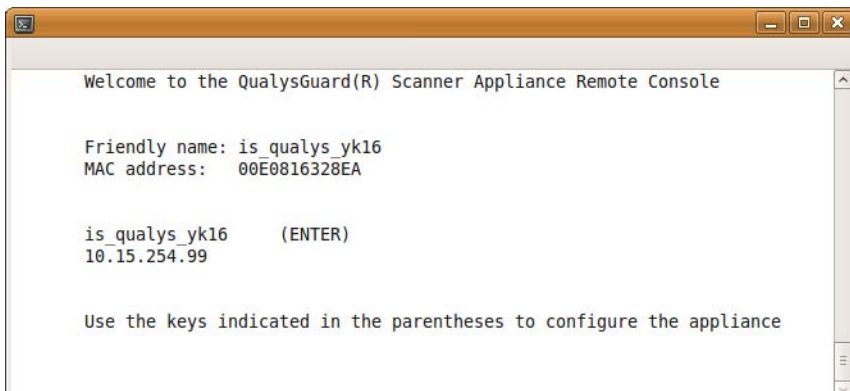

Figure 3-2. Scanner Appliance Remote Console User Interface

Menus and Navigation

This section describes the Scanner Appliance main menu, how to navigate through the Scanner Appliance user interface including menu options and screens, and how to enter information to set configurations.

Scanner Appliance Main Menu

To access the Scanner Appliance main menu, press ENTER when the Scanner Appliance name and IP address are displayed. The first menu option displayed is **SETUP NETWORK**. Note: An important menu change for Scanner Appliance software version 2.6 is shown.

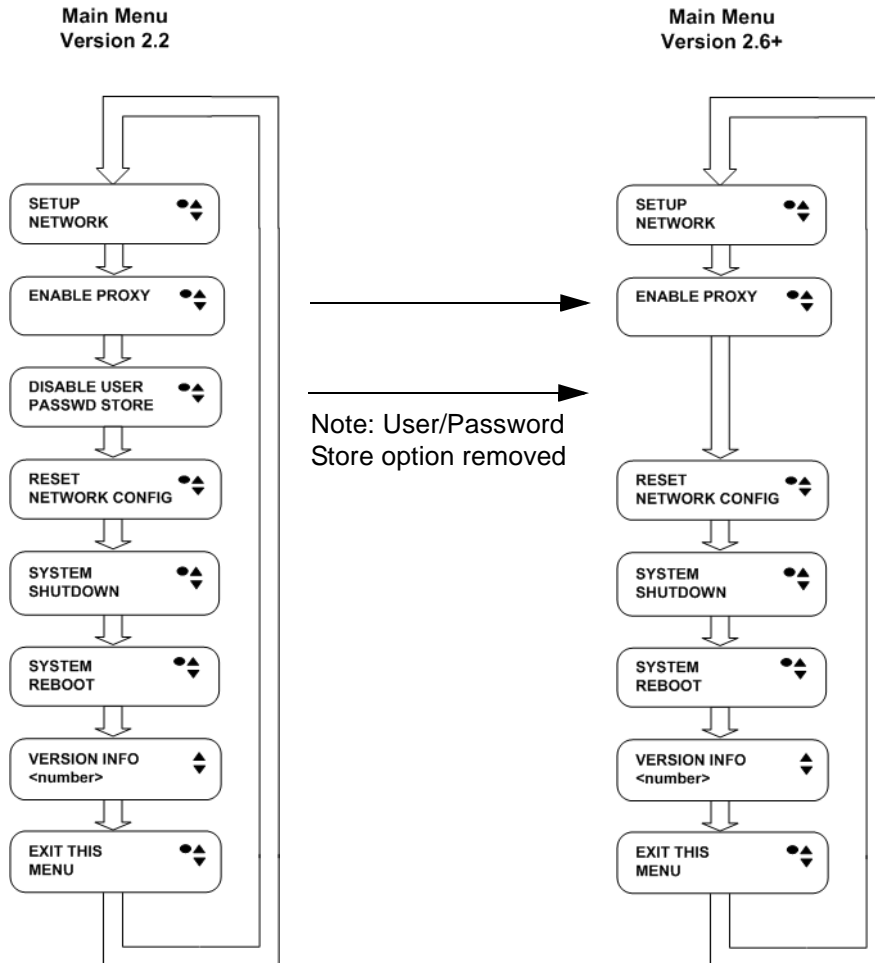

Figure 3-3. Scanner Appliance Main Menu

To move up through the menu options, press the Up arrow. To move down through the menu options, press the Down arrow. To select an option, press ENTER. See “Navigating Through the User Interface” below for more information.

To exit the Scanner Appliance main menu, press the down arrow button until the **EXIT THIS MENU** option appears, and then press ENTER.





Software Version

The **VERSION INFO** screen displays the current version number of the Scanner Appliance system software that is installed on the appliance. The system software has multiple components, including a hardened Linux-based operating system.

Changes in the Scanner Appliance main menu appear depending on which Scanner Appliance software version is running on the appliance. Qualys pushes new software versions through the Scanner Appliance software update mechanism. Please contact Support for information about the schedule for the software distribution.

Navigating Through the User Interface

Each Scanner Appliance screen displays one or more indicators in the top right corner, indicating the navigation options available from the current screen.

LCD Button	Remote Console Key	Description
	ENTER	Confirm a selection. After you press ENTER, another screen appears.
	RIGHT	Move the cursor to the right in an entry field.
	LEFT	Move the cursor to the left in an entry field.
	UP	Used to: — Increase the value in an entry field — Move up through menu options — Cancel a confirmation message
	DOWN	Used to: — Decrease the value in an entry field — Move down through menu options

Note these important guidelines for using buttons: 1) Press one button at a time, 2) Do not hold down an arrow button (except as noted in guideline 3), instead press the arrow multiple times, and 3) When entering a user name or password, you can hold down the Up and Down arrow buttons to scroll through characters quickly.

Entering Information

The Scanner Appliance user interface (LCD and Remote Console) allow users to enter information in the fields provided using arrow keys. The Left and Right arrows move the cursor to the left and right and the Up and Down arrows are used to scroll through characters. Some fields allow certain characters to be entered. The character restrictions are described below.

The Remote Console interface is available only when the Scanner Appliance is running software version 2.4 (or later). The software version for your Scanner Appliance appears in the main menu in the **VERSION INFO** screen. See “Scanner Appliance Main Menu” for information.

Using the Remote Console interface, you have the option to enter characters using the VT100 terminal’s keyboard. The same character restrictions using the LCD user interface also apply using the Remote Console interface as described in the sections below.

Up and Down Arrows

Using the LCD user interface use the Up and Down arrows to enter characters in a field. Using the Remote Console interface you have the option to use the Up and Down arrows or to use your keyboard to enter characters.

In numeric entry fields, you press the Up and Down arrows to select a value between 0 and 9. When a numeric entry field is first displayed, a default value appears.

In text entry fields where you enter a user name and password, you press the Up and Down arrows to select a character (numeric, alphabetic, space, underscore or special character). In these fields, you can hold the Up arrow or the Down arrow to scroll through the available characters. When a text entry field is first displayed, the text entry field is blank (filled with spaces).

Scrolling through Characters

The QualysGuard user fields, **SA LOGIN** and **SA PASSWD**, and the Proxy user fields, **PROXY USER** and **PROXY PASSW**, allow you to select lower case letters, uppercase letters, numbers, space, and underscore. Some fields allow special characters. See “QualysGuard User Login and Password” and “Proxy User Name” below for details.

Press the Up arrow to scroll through characters in ascending order. Starting from the space character, the characters appear in this order: lowercase letters (a to z), space, numbers (0 to 9), underscore, special characters (for Proxy user name and password only), uppercase letters (A to Z).

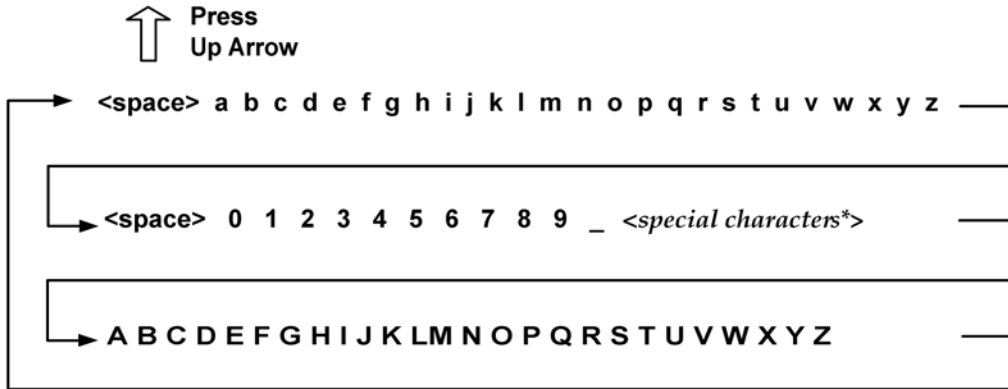

Figure 3-4. Scrolling characters in ascending order

Press the Down arrow to scroll through characters in descending order. Starting from the space character, the characters appear in this order: uppercase letters (Z to A), special characters (for Proxy user name and password only), underscore, numbers (9 to 0), space, lowercase letters (z to a).

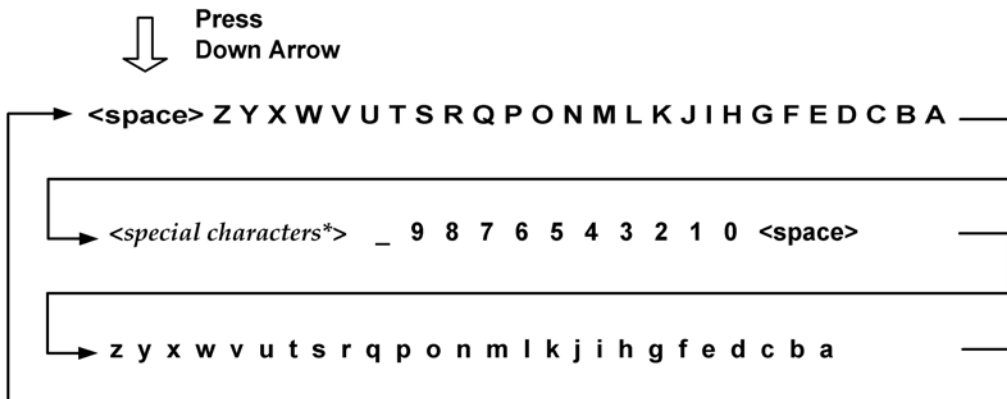

Figure 3-5. Scrolling characters in descending order

Space Character

When a text field entry contains fewer characters than the character positions on the interface screen, you must select the space character for the unused positions, before or after the field entry. Only the characters associated with the field entry and space characters may be included in a text field entry.

Embedded spaces are not permitted in text field entries, except in the Proxy password field.

The space character may be used to remove characters when editing text fields, except the Proxy password. To remove a character in an entry field using the LCD user interface, move the cursor on the character (using the Left and Right arrows), select the space character (using the Up and Down arrows) and then press ENTER. Any space characters entered appear in the interface screen until the next time you revisit the screen.

IP Addresses

Entry fields for IP addresses are pre-filled with values in this format: *nnn.nnn.nnn.nnn*

The IP address format displays values for each character position in all octets. When entering an IP address, you replace the three “n” digits for each octet as appropriate. If an octet has less than three digits, then the octet must include leading zeros. For example, to specify the IP address “194.55.176.2”, you input the IP address as “194.055.176.002”.

QualysGuard User Login and Password

The QualysGuard user fields, **SA LOGIN** and **SA PASSWD**, allow you to select lower case letters, upper case letters, numbers, space, and underscore. Some special characters may be entered in the **SA PASSWD** field.

In the QualysGuard password field, **SA PASSWD**, these special characters are allowed: underscore (_), hyphen (-), slash (/), exclamation (!), at sign (@), number sign (#), dollar sign (\$), percent (%), plus (+), and backslash (\). Use the Up and Down arrow keys to scroll through characters.

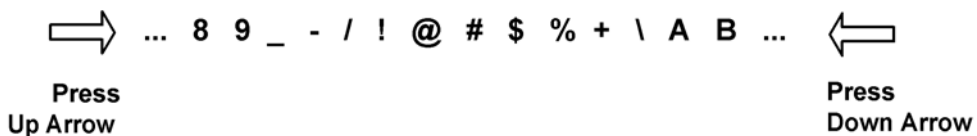

Figure 3-6. Special characters in the QualysGuard password field

The space character may be used to remove characters when editing the login name and password entries. See “Space Character” for further information.

Domain Name

The **DOMAIN NAME** field in the static IP address configuration allows you to enter the domain name for the DNS server (for example, mydomain.com). The domain name entry can have a maximum length of 32 characters. These characters are allowed: uppercase letters, numbers, underscore(_), and period (.).

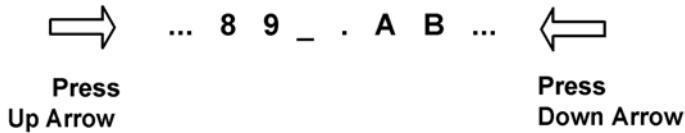

Figure 3-7. Special characters in the Domain Name field

The screen displays 16 characters of the **DOMAIN NAME** field entry and it scrolls left. For example, the first character of the domain name is hidden when the 17th character is entered. As each additional character is entered, the domain name scrolls left.

The space character may be used to remove characters when editing the domain name entry. See “Space Character” for further information.

Scanner Appliance software version 2.4 (or later) provides a shortcut for clearing a domain name entry. To do this, press the Left arrow and Right arrow at the same time.

Proxy User Name

For the Proxy user name in the **PROXY USER** field you may enter lower case letters, upper case letters, numbers, space, and underscore.

An entry in the **PROXY USER** field can have a maximum length of 32 characters.

Four special characters are allowed using software version 2.2: underscore (_), hyphen (-), backslash (\), and period (.). Using the LCD user interface, use the Up and Down arrow keys to scroll through characters.

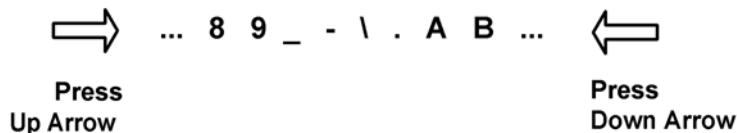

Figure 3-8. Special characters in the Proxy user field – Version 2.2

The at sign (@) is supported using software version 2.4 (or later).

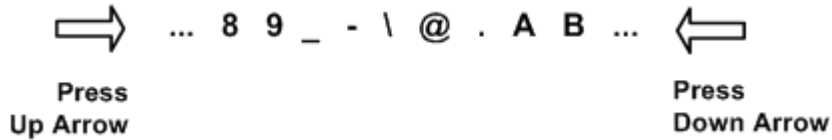

Figure 3-9. Special characters in the Proxy user field — Version 2.4 (or later)

The screen displays 16 characters of the **PROXY USER** field entry, and it scrolls left. For example, the first character of the Proxy user name is hidden when the 17th character is entered. As each additional character is entered, the Proxy user name scrolls left.

The format of a Proxy user entry is: "domain\user". If there is a backslash in the middle of the entry, the appliance interprets the string before the backslash as the domain name. No double backslashes (\) are needed in front of the "domain\user" format.

The space character may be used to remove characters when editing the Proxy user entry. See "Space Character" for further information.

Proxy Password

The **PROXY PASSW** allows you to enter lower case letters, upper case letters, numbers, space, and underscore.

An entry in the **PROXY PASSW** field can have a maximum length of 16 characters. Many special characters are allowed. These characters are shown in ascending order in the table shown on the next page.

Using the LCD interface, to scroll through characters 1 to 30, press the Up arrow. To scroll through characters in descending order, press the Down arrow.

Special Characters in the PROXY PASSW field

Order (ascending)	Character	Name	Order (ascending)	Character	Name
1	_	underscore	16	+	plus
2	-	hyphen	17	=	equal
3	\	backslash	18	(parenthesis left
4	/	slash	19)	parenthesis right
5		bar	20	{	brace left
6	~	tilda	21	}	brace right
7	!	exclamation	22	[bracket left
8	?	question	23]	bracket right
9	@	at sign	24	<	less
10	#	number sign	25	>	greater
11	\$	dollar	26	;	semicolon
12	%	percent	27	"	double quote
13	^	asciicircum	28	`	grave
14	&	ampersand	29	,	comma
15	*	asterisk	30	.	period

System Reboot and Shutdown

The sections below describe how to perform proper system reboot and system shutdown:

- System Reboot
- System Shutdown
- Restart Messages

Note: It is important to follow the proper system shutdown instructions described below. If you do not follow these instructions, file system corruption may occur.

System Reboot

To reboot the Scanner Appliance, follow these steps:

- 1 With the Scanner Appliance name and IP address displayed, press ENTER.
- 2 When the **SETUP NETWORK** menu option appears, press the Down arrow to navigate through the menu options.
- 3 When the **SYSTEM REBOOT** menu option appears, press ENTER to select the option.
- 4 When the **REALLY REBOOT SYSTEM?** prompt appears, press ENTER to confirm.

Review the confirmation messages starting with **REBOOTING SYSTEM** message. The **SCANNER APPLIANCE NAME-IP ADDRESS** is displayed after the Scanner Appliance makes a successful connection to the QualysGuard platform. This message indicates the Scanner Appliance is ready for scanning. If another message appears you need to activate the Scanner Appliance or troubleshoot the issue (see Appendix B, “Troubleshooting”) before scanning.

System Shutdown

Do not power off the Scanner Appliance before you shut down the system properly, as described below.

To shut down the Scanner Appliance, follow these steps:

- 1 With the Scanner Appliance name and IP address displayed, press ENTER.
- 2 When the **SETUP NETWORK** menu option appears, press the Down arrow to navigate through the menu options.
- 3 When the **SYSTEM SHUTDOWN** menu option appears, press ENTER.

- 4 When the **REALLY SHUTDOWN SYSTEM?** prompt appears, press ENTER to confirm.
- 5 **Important!** The Scanner Appliance should now power down within 60 seconds. When this message appears: “It’s now safe to unplug the box”, then you can safely unplug the Scanner Appliance.

Restart Messages

When you restart the Scanner Appliance, several messages appear during the startup process, as described below:

- 1 When the system is restarted, informational messages appear in the screen during the boot process. These messages appear in the order shown below:

```
Welcome to QualysGuard
Qualys Scanner is starting up...
Filesystem check in progress...
Qualys Scanner is coming up...
```

- 2 The appliance attempts to connect to the QualysGuard platform using its configuration. During this phase, these messages appear in the order shown below:

```
CONTACTING QUALYS
Filesystem check in progress...
CONTACTING QUALYS
```

- 3 The **SCANNER APPLIANCE NAME-IP ADDRESS** is displayed after the Scanner Appliance makes a successful connection to the QualysGuard platform. This indicates the Scanner Appliance is ready for scanning. If another message appears you need to take some action before you can start scanning:
 - **USER LOGIN** — Log into the Scanner Appliance (appears only when the appliance is running version 2.2).
 - **ACTIVATION CODE** — The Scanner Appliance needs to be activated (appears only when the appliance is running version 2.4 or later). Refer to the Quick Start for instructions.
 - **NETWORK ERROR** — A network error prevented the Scanner Appliance from making a connection to the QualysGuard platform. This issue must be resolved before scanning. See Appendix B, “Troubleshooting” for assistance.

Qualys User/Password Store (Version 2.2)

The **DISABLE USER PASSWD Store** menu option appears only when the Scanner Appliance is running software version 2.2. The software version for your Scanner Appliance appears in the main menu in the **VERSION INFO** screen.

When software version 2.4 (or later) is installed on the Scanner Appliance, you activate the Scanner Appliance using an activation code. This code is unique to your Scanner Appliance and displayed automatically after you complete Step 2 of the Quick Start, which is described in Chapter 1.

A Scanner Appliance running software version 2.2 is pre-configured with the Qualys user/password store enabled. When enabled, the system does not prompt the user to enter a QualysGuard user name and password after the Scanner Appliance is restarted. Instead, the system references the information in the local user/password store automatically, and then displays the Scanner Appliance name and IP address.

When the user/password store is enabled, login credentials are stored on the hard drive. Physical access to the appliance's internal hard drive could reveal the user name and password to an attacker.

The user/password store feature is available as a convenience, and it can be disabled at any time using the Scanner Appliance main menu. To disable this feature, follow these steps:

- 1 With the Scanner Appliance name and IP address displayed, press ENTER.
- 2 When the **SETUP NETWORK** menu option appears, press the Down arrow to navigate through the main menu options.
- 3 When the **DISABLE USER PASSWD STORE** menu option appears, press ENTER.
- 4 When the **REALLY DISABLE U/PASSWD STORE?** prompt appears, press ENTER to confirm the selection.

The next time you access the Scanner Appliance main menu, the **ENABLE USER/PASSWD STORE** option will appear, so that you can reactivate the user/password store feature if desired.

VLAN Interface Configuration

The Scanner Appliance supports VLAN trunking on the LAN interface for scanning traffic. VLAN trunking on the WAN interface is not supported. One VLAN interface configuration (802.1Q) may be configured using the Scanner Appliance user interfaces (LCD and Remote Console). Multiple VLANs may be configured using the QualysGuard web application.

It's possible to enable VLAN or DHCP on the appliance's LAN interface, not both. If you enable VLAN on the appliance, then you must enable a static IP address as well. When a VLAN configuration is provided and properly configured, the Scanner Appliance adds a VLAN tag to all scanning packets following the 802.1Q tagging protocol. The VLAN tag designates which VLAN the scanning traffic should be routed to.

A VLAN configuration that is defined in the Scanner Appliance interface is saved on the Scanner Appliance; whereas a VLAN configuration that is defined using the QualysGuard web application is saved on a server at the Qualys Security Operations Center (SOC) with your account information. With this release, there is no mechanism to relay VLAN configurations saved on the appliances to the QualysGuard web application. It's possible to add one VLAN configuration using the Scanner Appliance interface and additional VLANs using the QualysGuard web application.

Important! After you enable or disable a VLAN interface configuration, you always must complete the entire network configuration so that the Scanner Appliance can make a successful connection to the QualysGuard platform.

Configure VLAN

To configure the Scanner Appliance with a single VLAN interface on the LAN interface, follow these steps:

- 1 Go to the **SETUP NETWORK** menu option and press ENTER to continue.
- 2 Press the Down arrow one time. When the **ENABLE VLAN ON LAN** menu option appears, press ENTER to continue.
- 3 When the prompt **VLAN 0-4094** appears, specify the VLAN ID. The value "0000" appears in the screen by default. Specify the VLAN ID, and then press ENTER to continue.

Upon successful configuration, the **ENABLE STATIC IP ON LAN** menu option appears prompting you to specify the static IP address configuration. This configuration is required when a VLAN interface is enabled. To complete this configuration, follow the instructions provided in the section "Static IP Address Configuration."

When a VLAN interface is enabled, you will notice the **ENABLE DHCP ON LAN** menu option is not available.

Change VLAN

A VLAN configuration that you've added using the Scanner Appliance user interface (LCD and Remote Console) can be changed at any time. To do this, select the **CHANGE VLAN ON LAN** menu option from the **SETUP NETWORK** menu. Then enter another VLAN ID and press ENTER.

Disable VLAN

To disable a VLAN configuration, select the **CHANGE VLAN ON LAN** menu option from the **SETUP NETWORK** menu. Then enter the VLAN ID "0000" and press ENTER. After the configuration is disabled the **ENABLE DHCP ON LAN** menu option appears on the Scanner Appliance interface.

Configure VLANs using QualysGuard Web Application

The QualysGuard web application allows users to add, edit and remove custom VLAN and static route configurations for each Scanner Appliance. Up to 99 VLANs and 99 static routes may be defined per appliance.

For information on how to set up VLAN trunking using the QualysGuard user interface, please refer to the QualysGuard online help.

When a VLAN configuration exists on a Scanner Appliance because it was defined using the Scanner Appliance user interface (LCD and Remote Console), please note:

- The VLAN cannot be viewed, edited or deleted using the QualysGuard user interface.
- The VLAN can be edited or deleted only using the Scanner Appliance interface.
- Additional VLANs can be added for the Scanner Appliance using the QualysGuard user interface.
- A VLAN configuration defined for the Scanner Appliance using the QualysGuard user interface will not override a VLAN configuration defined using the Scanner Appliance interface. In a case where a user defines a VLAN via the user interface that is identical to a VLAN defined via the Scanner Appliance interface, the Scanner Appliance-configured VLAN will be saved and the other VLAN will be ignored.

Static IP Address Configuration

If DHCP is not on your network, you must enable the Scanner Appliance with a static IP address using the **ENABLE STATIC IP ON LAN** menu option. One of these configurations is required before you go to Step 2 of the Quick Start.

Entry fields for IP addresses used in the static IP address configuration are pre-filled with three digits for all octets, and you must enter a value for each digit. For example, to specify the IP address “176.34.20.5”, you input the IP address as “176.034.020.005”. See “IP Addresses” (earlier in this chapter) for more information.

Enable Static IP Address on the LAN Interface

When enabling a static IP address on the LAN interface, you must enter network configuration settings for the Scanner Appliance so that the appliance can communicate with the QualysGuard platform. Also, you have the option to enter some network settings for informational purposes.

To enable a static IP address on the LAN interface for the Scanner Appliance, follow these steps:

- 1 Go to the **SETUP NETWORK** menu option and press ENTER to continue.
- 2 Press the Down arrow until the **ENABLE STATIC IP ON LAN** menu option appears. Then press ENTER to continue.
- 3 When the **CFG LAN STATIC NETWORK PARAMS?** prompt appears, press ENTER to continue. Or press the Up arrow to quit this procedure and return to the **SETUP NETWORK** menu option.

Static IP Address Parameters

The Scanner Appliance user interface (LCD and Remote Console) allows users to enter information in the fields provided using the arrow keys. Use the Left and Right arrows to move the cursor to the left and right, and use the Up and Down arrows to scroll through characters (see “Entering Information” earlier in this chapter). With the Remote Console interface, you have the option to enter characters using the VT100 terminal’s keyboard.

- 1 When the **LAN IP ADDR** prompt appears, enter the static IP address, and then press ENTER to continue.
- 2 When the **LAN NETMASK** prompt appears, use the Up and Down arrows to scroll to the desired netmask value. For information about netmask values, see “Netmask Entry for Static Network Parameters” on page 49. After selecting a netmask value, press ENTER to continue.
- 3 When the **LAN GATEWAY** prompt appears, enter the gateway IP address, and then press ENTER to continue.

- 4 When the **LAN DNS1** prompt appears, enter the IP address for the primary DNS server, and then press ENTER to continue.
- 5 When the **LAN DNS2** prompt appears, enter the IP address for the secondary DNS server. This entry is optional. Press ENTER to continue.
- 6 Next are three optional network settings, used for informational purposes only. These appliance settings are not used to access the internal network for scanning or the QualysGuard platform for software updates. To skip these settings, press ENTER three times.
 - When the **LAN WINS1** prompt appears, enter the IP address for the primary WINS server, if any. Press ENTER to continue.
 - When the **LAN WINS2** prompt appears, enter the IP address for the secondary WINS server, if any. Press ENTER to continue.
 - When the **DOMAIN NAME** prompt appears, enter the domain name for the DNS server (for example, mydomain.com). Press ENTER to continue.
- 7 When the **REALLY SET LAN STATIC NETWORK?** prompt appears, press ENTER to continue. Or press the Up arrow to quit this procedure and return to the **SETUP NETWORK** menu option.
- 8 Review the confirmation messages. The Scanner Appliance attempts to make a connection to the QualysGuard platform using the new configuration. Upon success the **SCANNER APPLIANCE NAME-IP ADDRESS** message appears and the static IP address is enabled.

Messages after Static IP Configuration

The **SCANNER APPLIANCE NAME-IP ADDRESS** message appears if the Scanner Appliance made a successful connection to the QualysGuard platform using the new configuration. When this is displayed you are ready to start scanning.

The **USER LOGIN** prompt (software version 2.2) appears if the Scanner Appliance made a successful connection to the QualysGuard platform, however login to the appliance is required. Please see the Quick Start.

The **ACTIVATION CODE** prompt (software version 2.4 or later) appears if the Scanner Appliance made a successful connection to the QualysGuard platform, however the appliance has not been activated. Please see the Quick Start.

A network error appears if the Scanner Appliance failed to make a connection to the QualysGuard platform. A network error may occur because the static IP parameters you entered are incorrect, or they do not match the static IP configuration on your network. See Appendix B, “Troubleshooting” for help with troubleshooting this issue.

Netmask Entry for Static Network Parameters

When entering static network parameters, you will notice that the cursor does not appear after the **LAN NETMASK** prompt and you cannot enter characters in the entry field. At first, the netmask “255.255.255.000” appears. Use the Up and Down arrows to scroll through valid netmasks. When the appropriate netmask value appears, press ENTER to confirm.

Possible netmask values are listed below. If you press the Down arrow, the values appear in this order: “255.255.255.000”, “255.255.254.000”, “255.255.252.000... If you press the Up arrow, the values appear in this order: “255.255.255.000”, “255.255.255.128”, “255.255.255.192”...

Scrolling netmask values in the Netmask field

Order (ascending)	Netmask value	Order (ascending)	Netmask value
1	255.255.255.000	16	255.128.000.000
2	255.255.254.000	17	255.000.000.000
3	255.255.252.000	18	254.000.000.000
4	255.255.248.000	19	252.000.000.000
5	255.255.240.000	20	248.000.000.000
6	255.255.224.000	21	255.000.000.000
7	255.255.192.000	22	224.000.000.000
3	255.255.128.000	23	192.000.000.000
9	255.255.000.000	24	128.000.000.000
10	255.254.000.000	25	255.255.255.252
11	255.252.000.000	26	255.255.255.248
12	255.248.000.000	27	255.255.255.240
13	255.240.000.000	28	255.255.255.224
14	255.224.000.000	29	255.255.255.192
15	255.192.000.000	30	255.255.255.128

Interface — Enable Static IP on LAN

A map of the Scanner Appliance interface used to enable a static IP address starting from the **SETUP NETWORK** menu option is shown below.

(*) One option may be enabled: **ENABLE VLAN ON LAN** or **ENABLE DHCP ON LAN**. After one option is enabled, the other option disappears from the **SETUP NETWORK** menu.

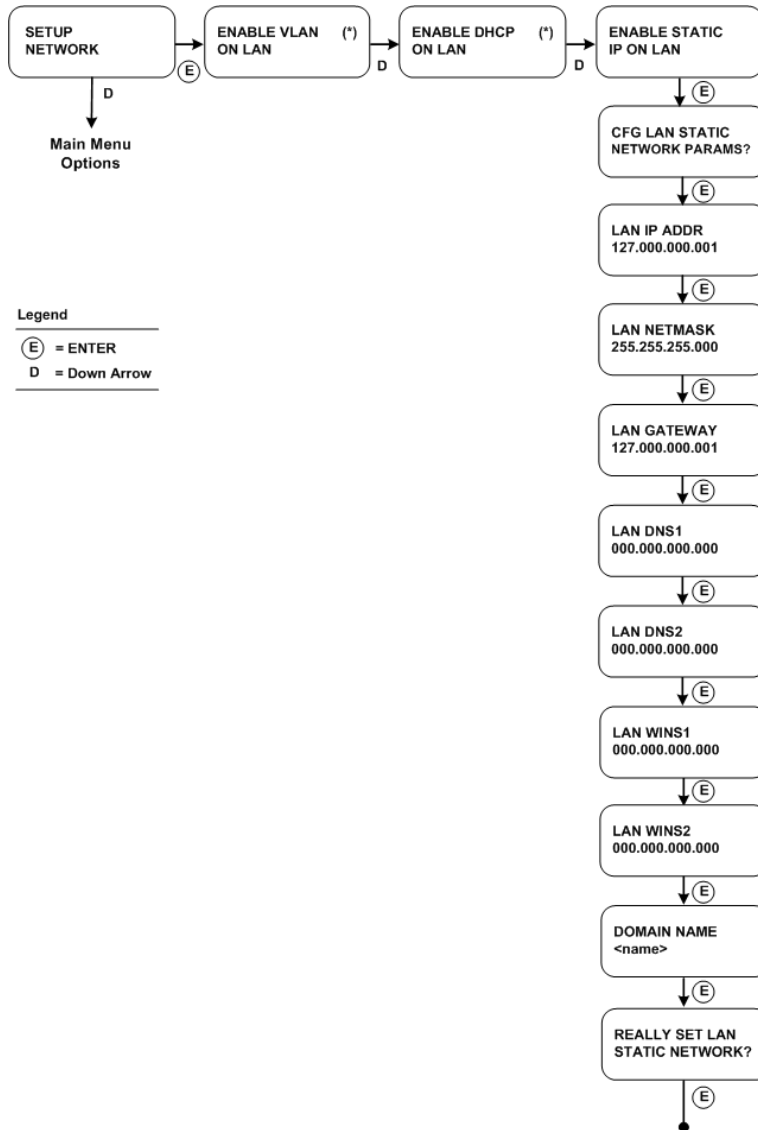

Figure 3-10. User Interface for Enable Static IP on LAN

Proxy Configuration

If the Scanner Appliance is behind a Proxy server, you need to enable a Proxy configuration using the **ENABLE PROXY** menu option. Authentication (Basic or NTLM) of the Scanner Appliance connection to your Proxy server can be enabled by configuring the Proxy user and password fields.

The Scanner Appliance uses Secure Sockets Layer (SSL) protocol (HTTPS) to secure its connection to the QualysGuard web application, in a similar way that a web browser does to a secure web server. If the QualysGuard connection must pass through a Proxy server, then you must enable the Proxy option on the Scanner Appliance. This configuration re-directs QualysGuard outbound connections through the Proxy server.

Your Proxy server must be configured to tunnel or pass through the SSL session to the QualysGuard web application. This ensures a secured end-to-end connection. SSL bridging or tunnel termination must not be configured in your Proxy server when supporting the Scanner Appliance.

Enable Proxy

To configure the Scanner Appliance with Proxy support, follow these steps:

- 1 Go to the **SETUP NETWORK** menu option.
- 2 Press the Down arrow until the **ENABLE PROXY** menu option appears. Then press ENTER to continue.
- 3 When the **CONFIG PROXY PARAMETERS** prompt appears, press ENTER to continue. Or press the Up arrow two times to quit this procedure and return to the **SETUP NETWORK** menu option.

Proxy Parameters

Enter Proxy parameters using the Up and Down arrows to scroll through characters. See “Entering Information.”

- 1 When the **IP ADDRESS** prompt appears, enter the Proxy server’s IP address. The gateway IP address appears in the screen by default. Use the Scanner Appliance interface to enter the Proxy server’s IP address, and then press ENTER to continue.

Octets: The IP address entry is pre-filled with three digits for all octets, and you must enter a value for each digit. For example, to specify the IP address “176.34.20.5”, you input the IP address as “176.034.020.005”. See “IP Addresses” for information.

- 2** When the **PROXY PORT:** prompt appears, enter the port number assigned to the Proxy server. Port “0443” appears in the screen by default. Confirm that the port number shown is correct or enter a different one, if necessary. When the correct port number appears, press ENTER to continue.
- 3** When the **PROXY USER:** prompt appears, enter the user name for Proxy authentication. If authentication is not enabled at the Proxy level, leave the entry field blank. Press ENTER to continue.

Supported Characters: Lower case letters, upper case letters, numbers, and space. These special characters may be entered: underscore (_), hyphen (-), backslash (\), and period (.).

- 4** When the **PROXY PASSW** prompt appears, enter the password for Proxy authentication. If authentication is not enabled at the Proxy level, leave the entry field blank. Press ENTER to continue.

Supported Characters: Lower case letters, upper case letters, numbers, and space. Many special characters may be entered for the Proxy password. See “Proxy Password” (on page 40) for information.

- 5** When the **REALLY ENABLE PROXY?** prompt appears, press ENTER to continue. Or press the Up arrow two times to quit this procedure and return to the **SETUP NETWORK** menu option.
- 6** Review the confirmation messages. The **ENABLING PROXY SUPPORT** message appears followed by other messages while the Scanner Appliance attempts to make a connection to the QualysGuard platform using the new configuration.

Upon success the **SCANNER APPLIANCE NAME-IP ADDRESS** message appears and the configured proxy is now confirmed working and being used. See “Messages after Proxy Configuration” for more information and help with troubleshooting.

Interface — Enable Proxy

The Scanner Appliance user interface to enable Proxy support is shown below.

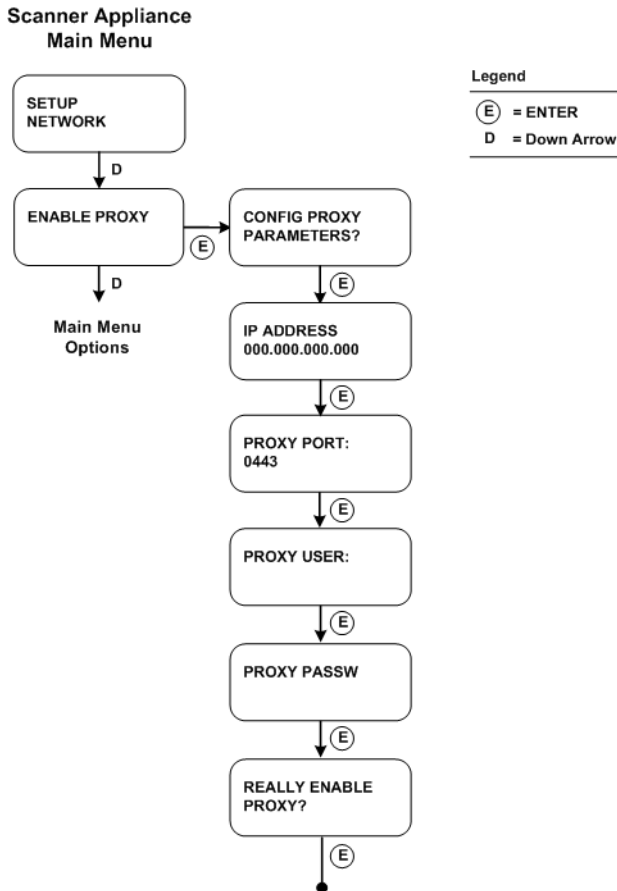

Figure 3-11. User Interface for Enable Proxy

Change/Disable Proxy

Once a Proxy configuration is enabled, the Proxy settings are stored on the Scanner Appliance. You can change or disable these settings at any time.

To change Proxy parameters, follow these steps:

- 1 Go to the **SETUP NETWORK** menu option.
- 2 Press the Down arrow until the **CHANGE PROXY PARAMS** menu option appears. Then press ENTER to continue.

- 3** Follow the prompts and messages in the Scanner Appliance interface to change the existing Proxy parameters. Existing parameters are displayed in each screen. Change and confirm each parameter. If a parameter has not changed, press ENTER to view the next parameter.
- 4** When the **REALLY ENABLE PROXY?** prompt appears, press ENTER to continue. Or press the Up arrow two times to quit this procedure and return to the **SETUP NETWORK** menu option.
- 5** Review the confirmation messages. The **ENABLING PROXY SUPPORT** message appears followed by others. See “Messages after Proxy Configuration” for more information and help with troubleshooting.

To disable Proxy parameters, follow these steps:

- 1** Go to the **SETUP NETWORK** menu option.
- 2** Press the Down arrow until the **DISABLE PROXY** menu option appears. Then press ENTER to continue.
- 3** When the **REALLY DISABLE PROXY?** prompt appears, press ENTER to continue. Or press the Up arrow two times to quit this procedure and return to the **SETUP NETWORK** menu option.
- 4** Review the confirmation messages. See “Messages after Proxy Configuration” for more information and help with troubleshooting.

Interface — Change Proxy Parameters

The Scanner Appliance user interface to change Proxy parameters is shown below.

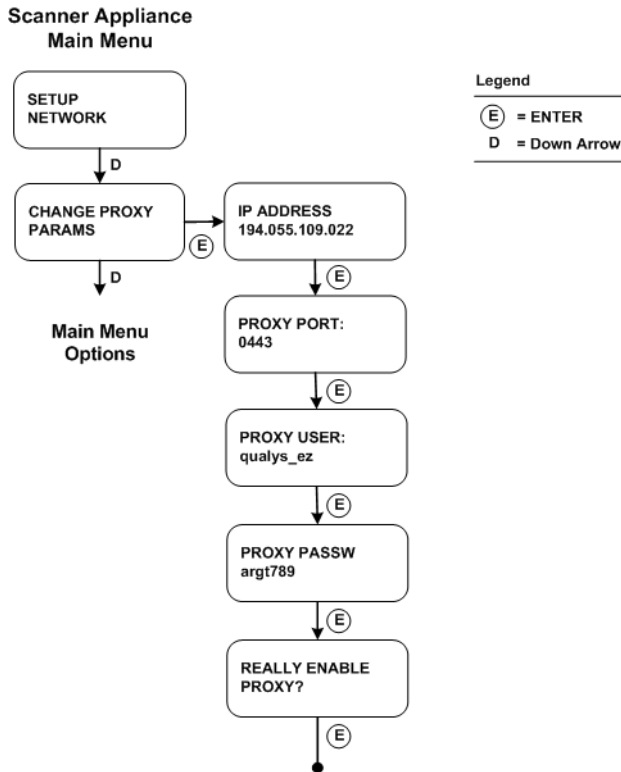

Figure 3-12. User Interface for Change Proxy Parameters

Messages after Proxy Configuration

The **SCANNER APPLIANCE NAME-IP ADDRESS** message appears if the Scanner Appliance made a successful connection to the QualysGuard platform using the new configuration. When this is displayed you are ready to start scanning.

The **USER LOGIN** prompt appears if the Scanner Appliance made a successful connection to the QualysGuard platform, however the appliance has not been activated. See Step 3 in the Quick Start and follow the instructions to activate the Scanner Appliance.

A network error appears if the Scanner Appliance failed to make a connection to the QualysGuard platform. A network error may occur because the Proxy parameters you entered are incorrect, or they do not match the Proxy configuration on your network. See Appendix B, “Troubleshooting” for help with troubleshooting this issue.

Split Network Configuration

The QualysGuard Scanner Appliance provides two network traffic configurations: Standard and Split. The Standard configuration is enabled by default. You may enable the Split network configuration using menu options on the **SETUP NETWORK** menu.

In the Standard network configuration, the LAN RJ45 Ethernet connector services both scanning traffic and management traffic to the QualysGuard platform over the Internet.

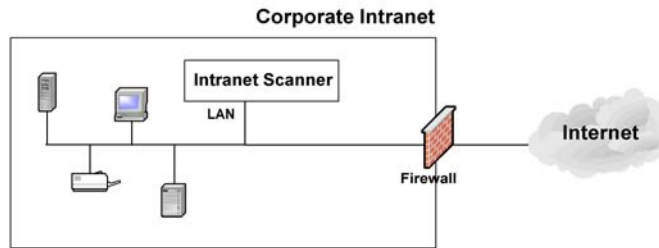

Figure 3-13. Standard network traffic configuration (default)

In the Split network configuration all Scanner Appliance management traffic, which includes scan/map job pickup, scan/map data upload, software updates and health checks are routed through the WAN port, whereas scan traffic uses the LAN port. This configuration enables the use of Scanner Appliances in networks that do not have direct Internet access.

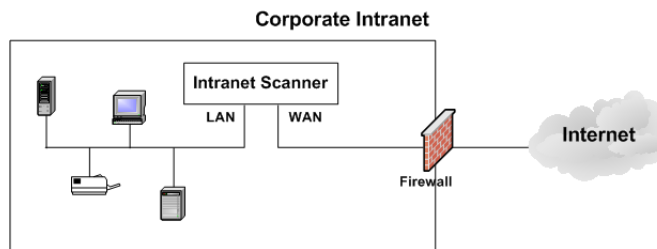

Figure 3-14. Split network traffic configuration

No internal traffic is routed or bridged to the WAN port and no management traffic is routed or bridged to the LAN port.

Check the Appliance Configuration

Check the Scanner Appliance configuration before you configure the WAN interface, as described below.

Check the LAN Interface Configuration

The Scanner Appliance must be configured with DHCP or a static IP address on the LAN interface, as described in the Quick Start. If a static IP address configuration is required, be sure that you enable the static IP configuration before the split network configuration.

Check the Network Connection

Check to be sure that network connection to both the LAN and WAN ports on the Scanner Appliance have been set up properly. For instructions, see Step 1 of the Quick Start on page 13.

Important! If the Scanner Appliance is powered on and connected to the LAN port only, power down the Scanner Appliance before you connect the second Ethernet cable to the WAN port.

Enable the WAN Interface

The WAN interface may be enabled with DHCP or a static IP address. To enable the WAN interface, select the **SETUP NETWORK** menu option and follow these steps:

- 1 Press the Down arrow until the **ENABLE WAN INTERFACE** menu option appears. Then press ENTER to continue.
- 2 Enable DHCP or a static IP address on the WAN interface, following the instructions in the next sections:
 - “Enable DHCP on the WAN Interface”
 - “Enable Static IP on the WAN Interface”

Split network configuration is not enabled until you enable DHCP or a static IP address configuration.

Enable DHCP on the WAN Interface

To configure the WAN interface with DHCP, follow these steps:

- 1 Go to the **ENABLE DHCP ON WAN** menu option and press ENTER to continue.
- 2 When the **REALLY ENABLE DHCP ON WAN?** prompt appears, press ENTER to continue. Or press the Up arrow two times to quit this procedure and return to the **SETUP NETWORK** menu option.
- 3 Review the confirmation message. When the **SCANNER APPLIANCE NAME-IP ADDRESS** appears you are ready to start scanning. If another message appears you need to complete the Quick Start or resolve the network error indicated.

Enable Static IP on the WAN Interface

To configure the WAN interface with a static IP address, follow these steps:

- 1 Go to the **ENABLE STATIC IP ON WAN** menu option and press ENTER to continue.
- 2 When the **CFG WAN STATIC NETWORK PARAMS?** prompt appears, press ENTER to continue. Or press the Up arrow to quit this procedure and return to the **SETUP NETWORK** menu option.
- 3 When the **WAN IP ADDR** prompt appears, enter the static IP address, and then press ENTER to continue.
- 4 When the **WAN NETMASK** prompt appears, use the Up and Down arrows to scroll to the desired netmask value. For information about netmask values, see “Netmask Entry for Static Network Parameters” on page 49. After selecting a netmask value, press ENTER to continue.
- 5 When the **WAN GATEWAY** prompt appears, enter the gateway IP address. Then press ENTER to continue.
- 6 When the **WAN DNS1** prompt appears, enter the IP address for the primary DNS. Then press ENTER to continue.
- 7 When the **WAN DNS2** prompt appears, enter the IP address for the secondary DNS. This entry is optional. Press ENTER to continue.
- 8 When the **REALLY SET WAN STATIC NETWORK?** prompt appears, press ENTER to continue. Or press the Up arrow to quit this procedure and return to the **SETUP NETWORK** menu option.
- 9 Review the confirmation message. When the **SCANNER APPLIANCE NAME-IP ADDRESS** message appears, you are ready to start scanning. If another message appears you need to complete the Quick Start or resolve the network error indicated.

Interface — Enable Static IP on WAN

A map of the Scanner Appliance user interface used to enable a static IP address on the WAN interface starting from the **SETUP NETWORK** menu option is shown below.

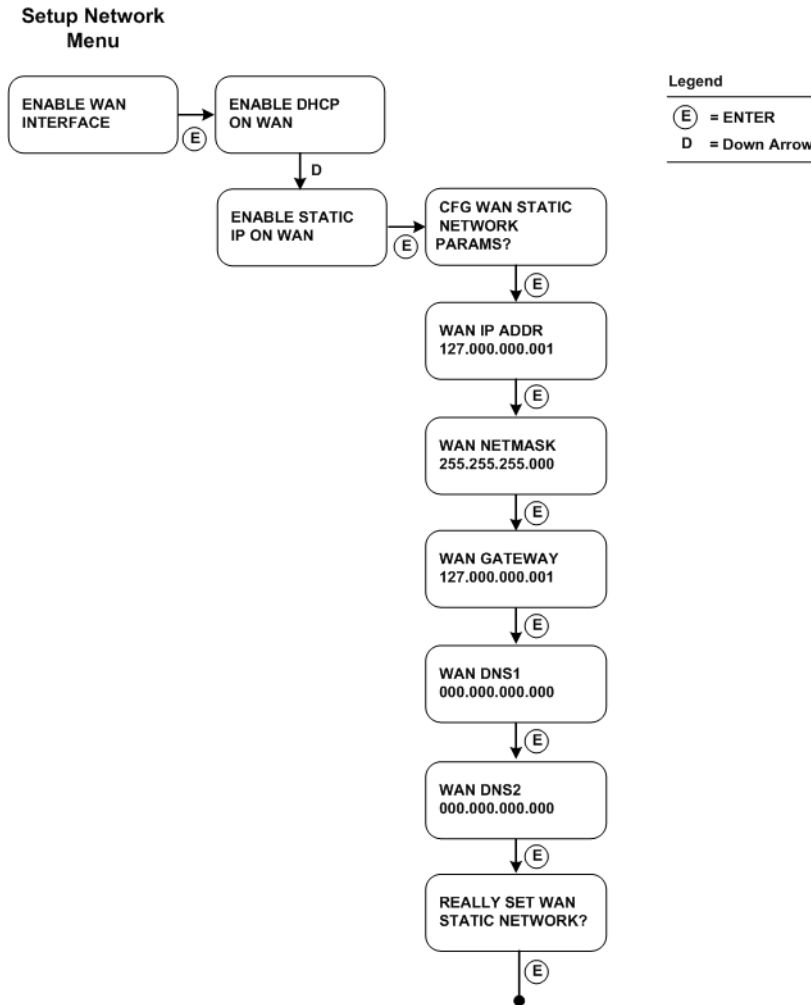

Figure 3-15. Enable Static IP Address on WAN Interface

Ethernet Port Configuration

The Scanner Appliance uses Ethernet autonegotiation on scanning and management ports. Most network devices have autonegotiation enabled. Locked-down port policies with autonegotiation disabled, such as forcing speed, duplex, and link capabilities, are outdated. This is due to the maturity of the autonegotiation technology as well as the rate of adoption by product vendors and consumers over many years.

In the rare and unusual case where autonegotiation is disabled, Ethernet port configuration on the Scanner Appliance is necessary to ensure that link syncing occurs between the Scanner Appliance and its link partners. The Ethernet port links on the appliance may be set to full-duplex 1GbaseT, 100baseT or 10baseT, or half-duplex 100baseT or 10baseT. The LAN and WAN port links (for split network configuration) may be set. The port link configuration on the Scanner Appliance must match the same configuration on the link partners. For example, if you have 100baseT full-duplex forced on devices, the same configuration must be enabled on the appliance.

In the absence of autonegotiation, link syncing between link partners may not occur and the link may not come up. Consequently, the Scanner Appliance data transmission may be slow and there may be high packet loss, leading to unreliable scan results.

Ethernet Port Settings

To configure the Scanner Appliance with an Ethernet port setting, select the **SETUP NETWORK** menu option and follow these steps:

- 1 Press the Down arrow to advance through the menu options. When the **ETHERNET PORT SETTINGS** menu option appears, press ENTER.
- 2 The **LAN PORT LINK** option is displayed along with the LAN port link setting in effect. Press the Right arrow to advance through the available port link settings.

Tips: Use the Left arrow to advance through the settings in reverse order. To quit this procedure and return to **SETUP NETWORK**, press the Up arrow two times.

Setting	Description
AUTO	Autonegotiation
1GbaseT/Full	1GbaseT (1 gigabit) full-duplex data transmission ¹
100baseT/Full	100baseT full-duplex data transmission
100baseT/Half	100baseT half-duplex data transmission
10baseT/Full	10baseT full-duplex data transmission
10baseT/Half	10baseT half-duplex data transmission

¹ The setting 1GbaseT/Full is available on Scanner Appliance model number QGSA-2120-C1 and later.

- 3 When the desired LAN port link setting is displayed, press ENTER to store the confirm the configuration setting.
- 4 When the **REALLY SET LAN TO <value>** prompt appears, press ENTER to store the configuration setting. Go to Step 9 unless WAN port configuration is necessary for split network configuration.

Split Network Configuration: When the Scanner Appliance has a split network configuration, you have the option to configure the WAN port link setting. To do this, follow the steps below.

- 5 Press the Down arrow one time. The **WAN PORT LINK** option is displayed along with the WAN port link setting in effect.
- 6 Press the Right arrow to advance through the available port link settings.

Tips: Use the Left arrow to advance through the settings in reverse order. To quit this procedure and return to **SETUP NETWORK**, press the Up arrow two times.

Setting	Description
AUTO	Autonegotiation
1GbaseT/Full	1GbaseT (1 gigabit) full-duplex data transmission ¹
100baseT/Full	100baseT full-duplex data transmission
100baseT/Half	100baseT half-duplex data transmission
10baseT/Full	10baseT full-duplex data transmission
10baseT/Half	10baseT half-duplex data transmission

¹ The setting 1GbaseT/Full is available on Scanner Appliance model number QGSA-2120-C1 and later.

- 7 When the desired WAN port link setting is displayed, press ENTER to confirm the configuration setting.
- 8 When the **REALLY SET WAN TO <value>** prompt appears, press ENTER to store the configuration setting.
- 9 Return to **SETUP NETWORK**.

A change to an Ethernet port setting takes effect right away.

Reset the Network Configuration

You have the option to reset the network configuration to the factory default using the **RESET NETWORK CONFIG** menu option on the Scanner Appliance user interface. For example, you may wish to reset the network configuration for troubleshooting purposes when setting up the Scanner Appliance. This is useful if you need to quickly set up the Scanner Appliance in a different location.

Important! When you reset the network configuration the service resets the network settings to the factory default. Any existing network settings that were customized by the user are removed. These include settings entered using the Scanner Appliance interface such as static IP address, Proxy support, the WAN interface configuration, Ethernet port configuration, and user/password store. After the reset, you must manually re-enter any required network configuration settings using the Scanner Appliance interface and ensure that the Scanner Appliance can connect to the QualysGuard platform. Without proper configuration, the Scanner Appliance cannot perform scans.

To reset the network configuration, follow these steps:

- 1 Go to the **SETUP NETWORK** menu option and press ENTER.
- 2 Press the Down arrow to advance through the menu options. When the **RESET NETWORK CONFIG** menu option appears, press ENTER.
- 3 When the **REALLY RESET NETWORK CONFIG?** prompt appears, press ENTER to continue. Or press the Up arrow to quit this procedure and return to the **SETUP NETWORK** menu.
- 4 Review the confirmation messages.

The Scanner Appliance attempts to connect to the QualysGuard platform using the default network configuration (DHCP enabled, no VLAN configuration, no Proxy configuration, no split network configuration, and no Ethernet port configuration).

In a case where the Scanner Appliance network configuration was customized (not identical to the default configuration provided by the service) before the reset, further network configuration is necessary in order for the Scanner Appliance to connect to the QualysGuard platform and perform scans. For assistance, see the Quick Start on page 11.

Changing the Network Configuration

When the Scanner Appliance has successfully connected to the network, the appliance stores the network configuration settings. These settings will appear as default parameters in the Scanner Appliance user interface. You can make updates to the network configuration at any time using the Scanner Appliance interface.

For example, to change from DHCP on the LAN interface to a static IP address on the LAN interface, go to the **SETUP NETWORK** menu option and then press ENTER. Press the Down arrow until the **ENABLE STATIC IP ON LAN** menu option appears. Follow the prompts and enter the static IP configuration.

Some network configuration settings have confirmation prompts. Be sure to confirm new configuration settings at these prompts. For example, if you are updating from DHCP on the LAN interface to a static IP on the LAN interface, enter the appropriate configuration settings following the prompts. At the **REALLY SET LAN STATIC NETWORK?** prompt, press ENTER to confirm the change.

You may choose to reset the network configuration to the factory default. See “Reset the Network Configuration” for instructions.

When a scan is in progress at the time of the configuration change, the scan task is cancelled and the message **CANCELING THE ONGOING SCAN** appears in the Scanner Appliance interface. This message is a reminder that a scan in progress will not complete, although partial scan results may be available. To avoid this situation check the “scan in progress” indicator (S1 LED) on the front panel prior to making changes to network settings.

The **NETWORK ERROR** message indicates that the Scanner Appliance was not able to make a connection to the QualysGuard platform using the new network configuration. If this message appears after changing the network configuration, refer to Appendix B, “Troubleshooting” for help with resolving the issue.

Interface Maps

This appendix includes maps of the Scanner Appliance interface for the most recent versions. These maps are included:

- Login Procedure — Version 2.2
- Interface Map — Version 2.2
- Interface Map — Version 2.6 or later
- Menus and User Configurations

For complete information about how to navigate the interface and enter values in text fields, please refer to Chapter 3, “Scanner Appliance Tour.”

Important! The software version installed on your Scanner Appliance determines whether certain features are available. The **VERSION INFO** screen displays the software version number currently running on the appliance.



Login Procedure — Version 2.2

The Scanner Appliance login procedure using software version 2.2 is shown below. This login procedure is part of Scanner Appliance software version 2.2.

The first time you power on the Scanner Appliance, you need to enter your QualysGuard user name and password using the interface. The second and subsequent times you restart the system, you are not prompted to enter your user name and password, assuming the user/password store remains enabled.

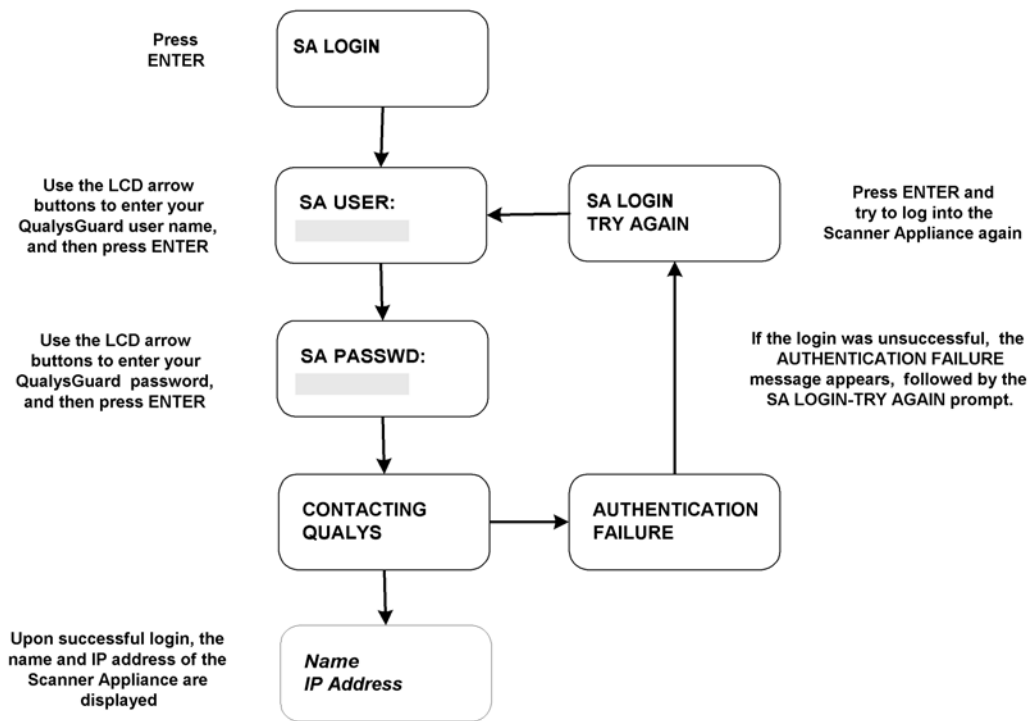

Figure A-1. Scanner Appliance Login Procedure — Version 2.2

Interface Map — Version 2.2

An interface map for Scanner Appliance system software version 2.2 is below.

(*) One option may be enabled: **ENABLE VLAN ON LAN** or **ENABLE DHCP ON LAN**. After one option is enabled, the other option disappears from the **SETUP NETWORK** menu.

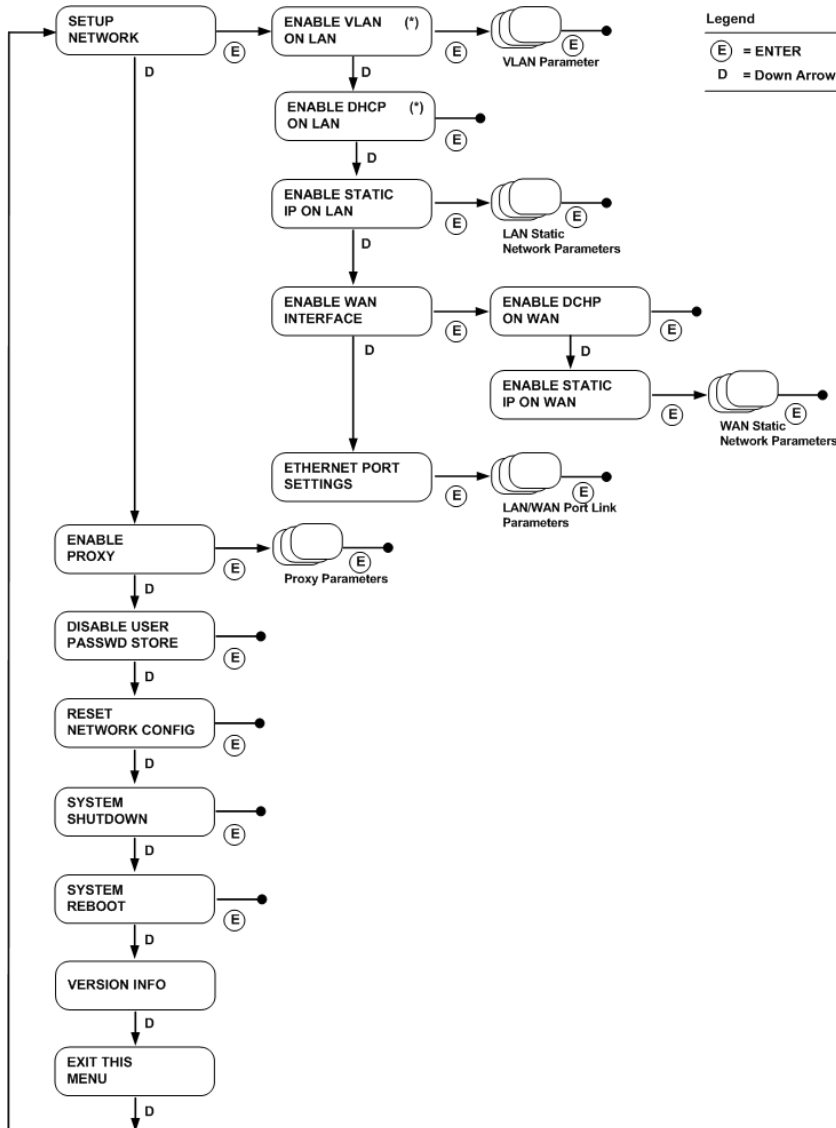

Figure A-2. Interface Map — Version 2.2

Interface Map — Version 2.6 or later

An interface map for Scanner Appliance system software version 2.6 (or later) is below.

(*) One option may be enabled: **ENABLE VLAN ON LAN** or **ENABLE DHCP ON LAN**. After one option is enabled, the other option disappears from the **SETUP NETWORK** menu.

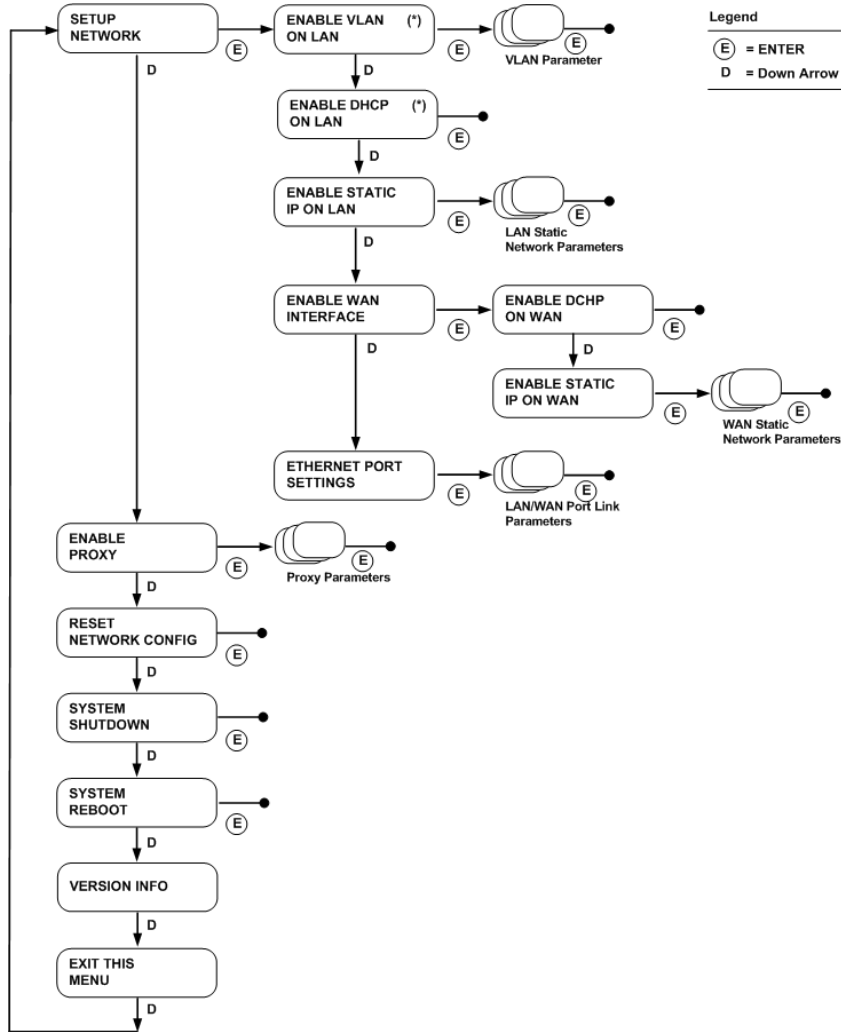

Figure A-3. Interface Map — Version 2.6 (or later)

Menus and User Configurations

These menu options appear automatically based on user configuration.

The **DISABLE USER PASSWD STORE** menu option is replaced with **ENABLE USER PASSWD STORE** when you disable the user/password store.

The **ENABLE PROXY** option changes to **CHANGE PROXY PARAMS** when you enable a Proxy configuration.

The **DISABLE PROXY PARAMS** option is added to the main menu when you enable a Proxy configuration.

On the **SETUP NETWORK** menu, the **ENABLE VLAN ON LAN** option is replaced with **CHANGE VLAN ON LAN** when you enable a VLAN interface configuration.

Appendix A – Interface Maps
Menus and User Configurations

Troubleshooting

This appendix describes troubleshooting techniques you can use to respond to errors and performance conditions when using the Scanner Appliance. These topics are covered:

- Network Configuration Guidelines
- Testing Network Connectivity
- “Network Error” Message
- “Activation Code–Network Err.” Message
- Network Error Codes
- Network Error Solutions
- “Login to Qualys–Guard Web First” Message
- “Authentication Failure” Message
- “Communication Failure” Message
- Proxy Support



Network Configuration Guidelines

Guidelines for troubleshooting the connectivity between the Scanner Appliance and the QualysGuard platform are provided below:

- 1 Lookup the meaning of the network error code that is displayed with the **NETWORK ERROR** message. See “Network Error Codes” below.
- 2 Be sure to enable all necessary configurations on the appliance. See “Network Configuration Guidelines” for assistance. This error message may appear because configurations are incomplete, incorrect, or are missing.
- 3 Follow the guidelines in “Testing Network Connectivity.”
- 4 Review the potential problems and related solutions in the “Network Error Solutions” section.

In many cases, a network error message indicates that additional configuration of the Scanner Appliance is required. For example, if your network does not have DHCP, you need to assign a static IP configuration. Configuration for Proxy support and/or split network configuration may be required.

See the network configurations below that include detailed set up steps for each.

Network Configurations with DHCP Present

Network configuration	Appliance set up steps
DHCP present No Proxy Standard network traffic	Plug in the appliance
DHCP present Proxy server Standard network traffic	Plug in the appliance Enable Proxy (see page 51)
DHCP present Split network traffic	Plug in the appliance Enable DHCP on WAN (see page 58)
DHCP present Proxy server Standard network traffic	Plug in the appliance Enable Proxy (see page 51) Enable DHCP on WAN (see page 58)

Network Configurations without DHCP Present

Network configuration	Appliance set up steps
DHCP not present No Proxy Standard network traffic	Plug in the appliance Enable Static IP on LAN (page 47)
DHCP not present Proxy server Standard network traffic	Plug in the appliance Enable Static IP on LAN (page 47) Enable Proxy (see page 51)
DHCP not present Split network traffic	Plug in the appliance Enable Static IP on LAN (page 47) Enable Static IP on WAN (page 58)
DHCP not present Proxy server Standard network traffic	Plug in the appliance Enable Static IP on LAN (page 47) Enable Proxy (see page 51) Enable Static IP on WAN (page 58)

Additional network configurations are supported, including a static IP address on LAN and DHCP on WAN, as well as DHCP on LAN and a static IP address on WAN.

Testing Network Connectivity

Methods you can use to test network connectivity are described below.

Use a Laptop. It is recommended that you test network connectivity to the QualysGuard platform using your laptop (or PC) as described below:

- 1 Take the laptop to the location where the Scanner Appliance will be installed and connect the laptop to the network, using the same network cable and port that will be used for the appliance.
- 2 Configure the laptop with the same network configuration that the Scanner Appliance will use (IP address, gateway, DNS server, etc.).
- 3 If the connection to the QualysGuard platform must pass through a proxy server, configure the laptop's web browser with proxy information.
- 4 Open a browser and try to log into your QualysGuard account.

When a successful connection is made, the QualysGuard **Log In** page appears.

Test DNS Name Resolution. You can test DNS name resolution from any machine connected to the same network as your Scanner Appliance. If DNS name resolution is working properly, server information is returned including the server name and IP address. (Note that “nslookup” is not available on all systems.)

“Network Error” Message

The **NETWORK ERROR** message indicates the Scanner Appliance attempted to connect to the QualysGuard platform via HTTPS (port 443) and failed. The message appears with an error code (see “Network Error Codes” below). Press ENTER to return to **SETUP NETWORK**.

Important! The Scanner Appliance is not functional until the **NETWORK ERROR** message is resolved.

You must resolve the issue and complete the Quick Start steps before scanning.

“Activation Code–Network Err.” Message

This message appears only when the Scanner Appliance is running software version 2.4 (or later).

The **ACTIVATION CODE/NETWORK ERR.** message indicates the Scanner Appliance has not been activated yet, and the appliance attempted to connect to the QualysGuard platform via HTTPS (port 443) and failed. The message appears with an error code (see “Network Error Codes” below). Press ENTER to return to **SETUP NETWORK**.

Important! The Scanner Appliance is not functional until the **ACTIVATION CODE/NETWORK ERR.** message is resolved.

You must resolve the issue and complete the Quick Start steps to activate the Scanner Appliance before scanning.

Network Error Codes

The error code displayed with a network error message provides specific information on the error to assist with troubleshooting. If you need further assistance with troubleshooting the issue, please identify the error code when you contact Qualys Support.

Network Error Code	Description
E00	Internal error (NTLM Proxy error)
E01	
E02	Internal error (Proxy error)
E03	Proxy configuration error
E04	No connectivity after the Proxy was disabled
E05	DNS lookup of the QualysGuard server failed (maybe network connectivity problem)
E06	Cannot reach the QualysGuard server via HTTPS
E07	Invalid LAN IP address or LAN gateway address

Network Error Code	Description
E08	Invalid WAN IP address or WAN gateway address
E09	LAN IP address or LAN gateway address cannot be 127.0.0.1
E10	Could not configure the LAN interface
E11	WAN IP address or WAN gateway address cannot be 127.0.0.1
E12	Could not configure the WAN interface
E13	DNS lookup of the QualysGuard server failed due to a network connectivity problem
E14	DNS lookup of the QualysGuard server failed during the “SA Login” or “Activation Code” step due to a network connectivity problem

More general error codes may be overwritten by more specific ones. For example, the appliance may return the error code E04 (No connectivity after the Proxy was disabled). After trying to connect for a while, the error code may be overwritten by E13 (DNS lookup of the QualysGuard server failed). When troubleshooting the network error, it's useful to be at the appliance to watch these error codes scroll by.

Network Error Solutions

The network connection failure may be due to one of the errors listed below.

Error:	The network cable is not plugged into the LAN port on the back panel properly.
Solution:	Check to be sure that the network cable is plugged into the LAN port properly. Also, if the administrative network interface is enabled, check to be sure that the network cable is plugged into the WAN port properly.
Error:	The Scanner Appliance does not communicate with the Gateway host that has been set up for the appliance. This failure can occur: <ol style="list-style-type: none"> 1) If the gateway host is down or unreachable. 2) If the IP address assigned to the appliance and/or gateway are incorrect, when the appliance has a static IP address configuration only.
Solution:	Check to be sure that the gateway host is up and running.
	If the appliance has a static IP address, navigate to the ENABLE STATIC IP ON LAN menu option, and follow the prompts to review the LAN IP ADDR and LAN GATEWAY values. If necessary, make changes to one or both of these IP addresses, and follow the prompts to save the configuration.

Error:	The IP addresses assigned to the primary DNS and secondary DNS are incorrect in the static network configuration for the appliance.
Solution:	Check to be sure that the IP addresses assigned to the primary and secondary DNS in the network configuration for the appliance are correct. Navigate to SETUP NETWORK , and follow the prompts after the ENABLE STATIC IP ON LAN menu option to check the values assigned.
Error:	Both the primary DNS and secondary DNS servers do not resolve QualysGuard platform DNS name. This error occurs if a Proxy configuration is not used.
Solution:	Check to be sure that at least one of the DNS servers (primary or secondary) is up and running. The DNS server must be able to resolve public domain names properly.
Error:	A firewall does not open SSL port 443 for outbound traffic. This may be due to a system time out, or to a firewall policy.
Solution:	Check with your network administrator to be sure that firewall policies allow outbound HTTPS traffic on port 443.
Error:	There is a problem with the service from your Internet carrier.
Solution:	Check with your IT department to be sure that your Internet service is running properly.
Error:	You entered a Proxy configuration for a Proxy server that does not meet the network configuration requirements for the Scanner Appliance.
Solution:	Check to be sure that your Proxy server meets the network configuration requirements, as described on page 11. See “Proxy Support” later in this appendix for more assistance.
Error:	One or more of the Proxy configuration parameters you entered (such as the port number, IP address, user name or password) does not match the actual Proxy configuration on your network.
Solution:	Check the Scanner Appliance interface to be sure that you have entered valid parameters for the Proxy configuration and make corrections as needed.

“Login to Qualys–Guard Web First” Message

This message appears only when the Scanner Appliance is running software version 2.2.

If you log into the Scanner Appliance for the first time before you accept the Qualys Service User Agreement (in the QualysGuard web application), the **LOGIN TO QUALYS-GUARD WEB FIRST** message appears.

You must log into the QualysGuard web application first, as described in Step 2 of the Quick Start, and accept the Service User Agreement, and then log into the Scanner Appliance. To resolve this error, complete Step 2 in the Quick Start before you log into the Scanner Appliance.

“Authentication Failure” Message

This message appears only when the Scanner Appliance is running software version 2.2.

If the login to the Scanner Appliance was unsuccessful, the **AUTHENTICATION FAILURE** message appears followed by the **SA LOGIN TRY AGAIN** message. This failure may be due to one of the errors listed below.

Error:	You did not use the same QualysGuard account to log into the QualysGuard web application and the Scanner Appliance.
Solution:	Be sure that you use the same QualysGuard user account to log into the QualysGuard application and the Scanner Appliance.

Error:	Your QualysGuard user account is not configured for use with the Scanner Appliance.
Solution:	Check whether your Scanner Appliance appears in the QualysGuard application. Log into the web application and view the Scanner Appliance list. To do this, select Scanner Appliances on the left menu under Tools.
	If your Scanner Appliance is not listed, please contact your Qualys account representative or Qualys Support.

Error:	Your QualysGuard user account is not configured for use with the Scanner Appliance.
Solution:	Your Scanner Appliance has a unique Scanner ID (hardware related), and this Scanner ID is assigned to your QualysGuard user account. If you have more than one appliance, you may log into the Scanner Appliance with the QualysGuard account that is set up for another appliance. Be sure that the QualysGuard account you use to log into the Scanner Appliance is the correct account for that specific appliance.
	Please contact Qualys Support if you need assistance with determining which QualysGuard account is appropriate for your Scanner Appliance.

“Communication Failure” Message

The **COMMUNICATION FAILURE** message appears if there is a network breakdown between the Scanner Appliance and the QualysGuard platform.

The communication failure may be due to one of these reasons: the network cable was unplugged from the Scanner Appliance, the local network goes down, or any of the network devices between the Scanner Appliance and the QualysGuard platform goes down.

Note the sequence of events following a network breakdown:

- If there are no scans and/or maps running on the appliance — The next time the appliance sends a polling request to the QualysGuard platform, the polling request fails, and then the **COMMUNICATION FAILURE** message appears.
- If there are scans and/or maps running on the appliance — The **COMMUNICATION FAILURE** message appears after the running scans and/or maps time out. Usually the S1 LED turns off after the scans and/or maps time out. If this message appears, it is recommended that you use the QualysGuard interface to cancel any running scans and/or maps and restart them to ensure that results are accurate.

After the network breakdown is resolved, the Scanner Appliance name and IP address appear automatically. Then you can start scans and maps. The **COMMUNICATION FAILURE** message may not disappear right away for the reasons described below.

The **COMMUNICATION FAILURE** message remains until the next time the appliance makes a successful polling request to the QualysGuard platform. There may be a lag time after the network is restored and before the appliance is back online, depending on when the next polling request is scheduled. Additional time is necessary for communications to be processed by a Proxy server if the appliance has a Proxy configuration.

For information about the polling interval preference, see “Edit Scanner Appliance Settings” in Chapter 2.

Proxy Support

The Scanner Appliance does not support Proxy servers in networking environments where the Proxy server IP address is dynamically assigned.

Tip: To determine whether your Proxy server uses scripts to dynamically assign the Proxy server IP address, check your browser. Using Internet Explorer 7 or 8, check the LAN settings (in Tools—>Internet Options—>Connections—>LAN Settings). If the “Use automatic configuration script” check box is selected, scripts are used to dynamically assign an IP address to the Proxy server. Using Firefox 3.0, you can check the network settings (in Tools—>Options—>Network—>Settings) to see the configuration.

SOCKS proxies are not supported.

While using a Scanner Appliance with an Proxy configuration, you may notice the following performance issues:

Lag Time for Polling — There may be a lag time before Scanner Appliance configuration changes take effect. Changes may take effect after a period of time that is significantly longer than the polling interval. This is because there is additional time necessary for communications to be processed by the Proxy server.

No results or incomplete results — If the Proxy server sets limits for the absolute session timeout and/or the amount of outbound data that can be sent from the Scanner Appliance, you may receive no results or incomplete results. It's possible that the QualysGuard service terminates without completing a map or scan if these limits are set and a large number of IPs are scanned.

LAN and WAN LEDs

The LAN and WAN link status LEDs (on the rear panel of the appliance, on the left side of each Ethernet socket) remain lit after the Scanner Appliance has been disconnected from the network. If you suspect that the network link to one or both interfaces is not up, reboot or restart the appliance. As a result, the LEDs will display the correct link status.

Safety Notices

Rack Mount Safety Notes (bracket kit described in Chapter 1):

- **Elevated Operating Ambient** — The ambient temperature of an operating rack environment will be greater than the room's ambient temperature. The unit must be installed in a rack where its operating ambient temperature does not exceed the unit's maximum ambient temperature.
- **Reduced Air Flow** — The unit must be installed in a rack which enables adequate air flow for the proper cooling of the unit.
- **Adequate Power** — The rack must be set up to ensure that an appropriate level and amount of power is available to the unit. The overall connection of the rack equipment to the supply circuit and the effect that overloading the supply circuit might have on overcurrent protection and supply wiring should also be considered.
- **Reliable Grounding** — Reliable grounding of rack equipment must be maintained. Particular attention should be given to supply connections other than direct connections to the branch circuit (for example, use of power strips).
- **Mechanical Loading** — The unit should be installed in a rack in a manner that does not create a hazardous condition due to uneven mechanical overloading.

Cautionary Notices:

The socket-outlet shall be installed near the equipment and shall be easily accessible.

Le socle de prise de courant doit être installé à proximité du matériel et doit être aisément accessible.

CAUTION: RISK OF EXPLOSION IF BATTERY IS REPLACED BY AN INCORRECT TYPE. DISPOSE OF USED BATTERIES ACCORDING TO THE INSTRUCTIONS.

ATTENTION: IL Y A RISQUE D'EXPLOSION SI LA BATTERIE EST REMPLACÉE PAR UNE BATTERIE DE TYPE INCORRECT. METTRE AU REBUT LES BATTERIES USAGÉES CONFORMÉMENT AUX INSTRUCTIONS.



APPENDIX D

Credits

Copyright 2002-2011 by Qualys, Inc. All rights reserved.

Qualys, Inc., 1600 Bridge Parkway, Redwood Shores, CA 94065.

Qualys, the Qualys logo, and QualysGuard are registered trademarks of Qualys, Inc. All other trademarks are the property of their respective owners.

Portions of the software embedded in the Scanner Appliance were developed by third parties and are governed by the terms and conditions detailed below:

Copyright 1999-2001 The OpenLDAP Foundation, Redwood City, California, USA. All Rights Reserved. Permission to copy and distribute verbatim copies of this document is granted.

OpenLDAP is a registered trademark of the OpenLDAP Foundation.

The OpenLDAP Public License
Version 2.7, 7 September 2001

Redistribution and use of this software and associated documentation ("Software"), with or without modification, are permitted provided that the following conditions are met:

1. Redistributions of source code must retain copyright statements and notices,
2. Redistributions in binary form must reproduce applicable copyright statements and notices, this list of conditions, and the following disclaimer in the documentation and/or other materials provided with the distribution, and
3. Redistributions must contain a verbatim copy of this document.

The OpenLDAP Foundation may revise this license from time to time. Each revision is distinguished by a version number. You may use this Software under terms of this license revision or under the terms of any subsequent revision of the license.

THIS SOFTWARE IS PROVIDED BY THE OPENLDAP FOUNDATION AND ITS CONTRIBUTORS "AS IS" AND ANY EXPRESSED OR IMPLIED WARRANTIES, INCLUDING, BUT NOT LIMITED TO, THE IMPLIED WARRANTIES OF MERCHANTABILITY AND FITNESS FOR A PARTICULAR PURPOSE ARE DISCLAIMED. IN NO EVENT SHALL THE OPENLDAP FOUNDATION, ITS CONTRIBUTORS, OR THE AUTHOR(S) OR OWNER(S) OF THE SOFTWARE BE LIABLE FOR ANY DIRECT, INDIRECT, INCIDENTAL, SPECIAL, EXEMPLARY, OR CONSEQUENTIAL DAMAGES (INCLUDING, BUT NOT LIMITED TO, PROCUREMENT OF SUBSTITUTE GOODS OR SERVICES; LOSS OF USE, DATA, OR PROFITS; OR BUSINESS INTERRUPTION) HOWEVER CAUSED AND ON ANY THEORY OF LIABILITY, WHETHER IN CONTRACT, STRICT LIABILITY, OR TORT (INCLUDING NEGLIGENCE OR OTHERWISE) ARISING IN ANY WAY OUT OF THE USE OF THIS SOFTWARE, EVEN IF ADVISED OF THE POSSIBILITY OF SUCH DAMAGE.



The names of the authors and copyright holders must not be used in advertising or otherwise to promote the sale, use or other dealing in this Software without specific, written prior permission. Title to copyright in this Software shall at all times remain with copyright holders.

Copyright 1998-2000 The OpenLDAP Foundation, Redwood City, California, USA. All rights reserved.

Redistribution and use in source and binary forms are permitted provided that this notice is preserved and that due credit is given to the University of Michigan at Ann Arbor. The name of the University may not be used to endorse or promote products derived from this software without specific prior written permission. This software is provided "as is" without express or implied warranty.

Portions Copyright (c) 1993 Regents of the University of Michigan.

Redistribution and use in source and binary forms are permitted provided that this notice is preserved and that due credit is given to the University of Michigan at Ann Arbor. The name of the University may not be used to endorse or promote products derived from this software without specific prior written permission. This software is provided "as is" without express or implied warranty.

Portions Copyright (c) 1994 Regents of the University of Michigan.

Redistribution and use in source and binary forms are permitted provided that this notice is preserved and that due credit is given to the University of Michigan at Ann Arbor. The name of the University may not be used to endorse or promote products derived from this software without specific prior written permission. This software is provided "as is" without express or implied warranty.

Portions Copyright (c) 1990 Regents of the University of Michigan.

Redistribution and use in source and binary forms are permitted provided that this notice is preserved and that due credit is given to the University of Michigan at Ann Arbor. The name of the University may not be used to endorse or promote products derived from this software without specific prior written permission. This software is provided "as is" without express or implied warranty.

Copyright (C) 2000 Novell, Inc. All Rights Reserved.

THIS WORK IS SUBJECT TO U.S. AND INTERNATIONAL COPYRIGHT LAWS AND TREATIES. USE, MODIFICATION, AND REDISTRIBUTION OF THIS WORK IS SUBJECT TO VERSION 2.0.1 OF THE OPENLDAP PUBLIC LICENSE, A COPY OF WHICH IS AVAILABLE AT [HTTP://WWW.OPENLDAP.ORG/LICENSE.HTML](http://www.openldap.org/license.html) OR IN THE FILE LICENSE IN THE TOP-LEVEL DIRECTORY OF THE DISTRIBUTION. ANY USE OR EXPLOITATION OF THIS WORK OTHER THAN AS AUTHORIZED IN VERSION 2.0.1 OF THE OPENLDAP PUBLIC LICENSE, OR OTHER PRIOR WRITTEN CONSENT FROM NOVELL, COULD SUBJECT THE PERPETRATOR TO CRIMINAL AND CIVIL LIABILITY.

Copyright (C) 1998-2002 Daniel Veillard. All Rights Reserved.

Permission is hereby granted, free of charge, to any person obtaining a copy of this software and associated documentation files (the "Software"), to deal in the Software without restriction, including without limitation the rights to use, copy, modify, merge, publish, distribute, sublicense, and/or sell copies of the Software, and to permit persons to whom the Software is furnished to do so, subject to the following conditions:

The above copyright notice and this permission notice shall be included in all copies or substantial portions of the Software.

THE SOFTWARE IS PROVIDED "AS IS", WITHOUT WARRANTY OF ANY KIND, EXPRESS OR IMPLIED, INCLUDING BUT NOT LIMITED TO THE WARRANTIES OF MERCHANTABILITY, FITNESS FOR A PARTICULAR PURPOSE AND NONINFRINGEMENT. IN NO EVENT SHALL THE DANIEL VEILLARD BE LIABLE FOR ANY CLAIM, DAMAGES OR OTHER LIABILITY, WHETHER IN AN ACTION OF CONTRACT, TORT OR OTHERWISE, ARISING FROM, OUT OF OR IN CONNECTION WITH THE SOFTWARE OR THE USE OR OTHER DEALINGS IN THE SOFTWARE.

Except as contained in this notice, the name of Daniel Veillard shall not be used in advertising or otherwise to promote the sale, use or other dealings in this Software without prior written authorization from him.

Copyright (C) 2000 Bjorn Reese and Daniel Veillard.

Permission to use, copy, modify, and distribute this software for any purpose with or without fee is hereby granted, provided that the above copyright notice and this permission notice appear in all copies.

THIS SOFTWARE IS PROVIDED "AS IS" AND WITHOUT ANY EXPRESS OR IMPLIED WARRANTIES, INCLUDING, WITHOUT LIMITATION, THE IMPLIED WARRANTIES OF MERCHANTABILITY AND FITNESS FOR A PARTICULAR PURPOSE. THE AUTHORS AND CONTRIBUTORS ACCEPT NO RESPONSIBILITY IN ANY CONCEIVABLE MANNER.

Copyright (C) 1995-1998 Eric Young (eay@cryptsoft.com). All rights reserved.

This package is an SSL implementation written by Eric Young (eay@cryptsoft.com). The implementation was written so as to conform with Netscapes SSL. This library is free for commercial and non-commercial use as long as the following conditions are aheared to. The following conditions apply to all code found in this distribution, be it the RC4, RSA, lhash, DES, etc., code; not just the SSL code. The SSL documentation included with this distribution is covered by the same copyright terms except that the holder is Tim Hudson (tjh@cryptsoft.com).

Copyright remains Eric Young's, and as such any Copyright notices in the code are not to be removed. If this package is used in a product, Eric Young should be given attribution as the author of the parts of the library used. This can be in the form of a textual message at program startup or in documentation (online or textual) provided with the package.

Redistribution and use in source and binary forms, with or without modification, are permitted provided that the following conditions are met:

1. Redistributions of source code must retain the copyright notice, this list of conditions and the following disclaimer.
2. Redistributions in binary form must reproduce the above copyright notice, this list of conditions and the following disclaimer in the documentation and/or other materials provided with the distribution.
3. All advertising materials mentioning features or use of this software must display the following acknowledgement:

"This product includes cryptographic software written by Eric Young (eay@cryptsoft.com)"

The word 'cryptographic' can be left out if the rouines from the library being used are not cryptographic related :-).

4. If you include any Windows specific code (or a derivative thereof) from the apps directory (application code) you must include an acknowledgement:

"This product includes software written by Tim Hudson (tjh@cryptsoft.com)"

THIS SOFTWARE IS PROVIDED BY ERIC YOUNG "AS IS" AND ANY EXPRESS OR IMPLIED WARRANTIES, INCLUDING, BUT NOT LIMITED TO, THE IMPLIED WARRANTIES OF MERCHANTABILITY AND FITNESS FOR A PARTICULAR PURPOSE ARE DISCLAIMED. IN NO EVENT SHALL THE AUTHOR OR CONTRIBUTORS BE LIABLE FOR ANY DIRECT, INDIRECT, INCIDENTAL, SPECIAL, EXEMPLARY, OR CONSEQUENTIAL DAMAGES (INCLUDING, BUT NOT LIMITED TO, PROCUREMENT OF SUBSTITUTE GOODS OR SERVICES; LOSS OF USE, DATA, OR PROFITS; OR BUSINESS INTERRUPTION) HOWEVER CAUSED AND ON ANY THEORY OF LIABILITY, WHETHER IN CONTRACT, STRICT LIABILITY, OR TORT (INCLUDING NEGLIGENCE OR OTHERWISE) ARISING IN ANY WAY OUT OF THE USE OF THIS SOFTWARE, EVEN IF ADVISED OF THE POSSIBILITY OF SUCH DAMAGE.

The licence and distribution terms for any publically available version or derivative of this code cannot be changed. i.e. this code cannot simply be copied and put under another distribution licence [including the GNU Public Licence.]

Copyright (c) 1999 The OpenSSL Project. All rights reserved. Redistribution and use in source and binary forms, with or without modification, are permitted provided that the following conditions are met:

1. Redistributions of source code must retain the above copyright notice, this list of conditions and the following disclaimer.
2. Redistributions in binary form must reproduce the above copyright notice, this list of conditions and the following disclaimer in the documentation and/or other materials provided with the distribution.
3. All advertising materials mentioning features or use of this software must display the following acknowledgment: "This product includes software developed by the OpenSSL Project for use in the OpenSSL Toolkit. (<http://www.OpenSSL.org/>)"
4. The names "OpenSSL Toolkit" and "OpenSSL Project" must not be used to endorse or promote products derived from this software without prior written permission. For written permission, please contact licensing@OpenSSL.org.
5. Products derived from this software may not be called "OpenSSL" nor may "OpenSSL" appear in their names without prior written permission of the OpenSSL Project.
6. Redistributions of any form whatsoever must retain the following acknowledgment:

"This product includes software developed by the OpenSSL Project for use in the OpenSSL Toolkit (<http://www.OpenSSL.org/>)"

THIS SOFTWARE IS PROVIDED BY THE OpenSSL PROJECT "AS IS" AND ANY EXPRESSED OR IMPLIED WARRANTIES, INCLUDING, BUT NOT LIMITED TO, THE IMPLIED WARRANTIES OF MERCHANTABILITY AND FITNESS FOR A PARTICULAR PURPOSE ARE DISCLAIMED. IN NO EVENT SHALL THE OpenSSL PROJECT OR ITS CONTRIBUTORS BE LIABLE FOR ANY DIRECT, INDIRECT, INCIDENTAL, SPECIAL, EXEMPLARY, OR CONSEQUENTIAL DAMAGES (INCLUDING, BUT NOT LIMITED TO, PROCUREMENT OF SUBSTITUTE GOODS OR SERVICES; LOSS OF USE, DATA, OR PROFITS; OR BUSINESS INTERRUPTION) HOWEVER CAUSED AND ON ANY THEORY OF LIABILITY, WHETHER IN CONTRACT, STRICT LIABILITY, OR TORT (INCLUDING NEGLIGENCE OR OTHERWISE) ARISING IN ANY WAY OUT OF THE USE OF THIS SOFTWARE, EVEN IF ADVISED OF THE POSSIBILITY OF SUCH DAMAGE.

This product includes cryptographic software written by Eric Young (eay@cryptsoft.com). This product includes software written by Tim Hudson (tjh@cryptsoft.com).

Appendix D — Credits

Copyright (c) 1999-2000 Damien Miller. All rights reserved.

Redistribution and use in source and binary forms, with or without modification, are permitted provided that the following conditions are met:

1. Redistributions of source code must retain the above copyright notice, this list of conditions and the following disclaimer.
2. Redistributions in binary form must reproduce the above copyright notice, this list of conditions and the following disclaimer in the documentation and/or other materials provided with the distribution.

THIS SOFTWARE IS PROVIDED BY THE AUTHOR "AS IS" AND ANY EXPRESS OR IMPLIED WARRANTIES, INCLUDING, BUT NOT LIMITED TO, THE IMPLIED WARRANTIES OF MERCHANTABILITY AND FITNESS FOR A PARTICULAR PURPOSE ARE DISCLAIMED. IN NO EVENT SHALL THE AUTHOR BE LIABLE FOR ANY DIRECT, INDIRECT, INCIDENTAL, SPECIAL, EXEMPLARY, OR CONSEQUENTIAL DAMAGES (INCLUDING, BUT NOT LIMITED TO, PROCUREMENT OF SUBSTITUTE GOODS OR SERVICES; LOSS OF USE, DATA, OR PROFITS; OR BUSINESS INTERRUPTION) HOWEVER CAUSED AND ON ANY THEORY OF LIABILITY, WHETHER IN CONTRACT, STRICT LIABILITY, OR TORT (INCLUDING NEGLIGENCE OR OTHERWISE) ARISING IN ANY WAY OUT OF THE USE OF THIS SOFTWARE, EVEN IF ADVISED OF THE POSSIBILITY OF SUCH DAMAGE.

Copyright (c) 2000 Markus Friedl. All rights reserved.

Redistribution and use in source and binary forms, with or without modification, are permitted provided that the following conditions are met:

1. Redistributions of source code must retain the above copyright notice, this list of conditions and the following disclaimer.
2. Redistributions in binary form must reproduce the above copyright notice, this list of conditions and the following disclaimer in the documentation and/or other materials provided with the distribution.

THIS SOFTWARE IS PROVIDED BY THE AUTHOR "AS IS" AND ANY EXPRESS OR IMPLIED WARRANTIES, INCLUDING, BUT NOT LIMITED TO, THE IMPLIED WARRANTIES OF MERCHANTABILITY AND FITNESS FOR A PARTICULAR PURPOSE ARE DISCLAIMED. IN NO EVENT SHALL THE AUTHOR BE LIABLE FOR ANY DIRECT, INDIRECT, INCIDENTAL, SPECIAL, EXEMPLARY, OR CONSEQUENTIAL DAMAGES (INCLUDING, BUT NOT LIMITED TO, PROCUREMENT OF SUBSTITUTE GOODS OR SERVICES; LOSS OF USE, DATA, OR PROFITS; OR BUSINESS INTERRUPTION) HOWEVER CAUSED AND ON ANY THEORY OF LIABILITY, WHETHER IN CONTRACT, STRICT LIABILITY, OR TORT (INCLUDING NEGLIGENCE OR OTHERWISE) ARISING IN ANY WAY OUT OF THE USE OF THIS SOFTWARE, EVEN IF ADVISED OF THE POSSIBILITY OF SUCH DAMAGE.

Copyright (c) 2000 Niels Provos. All rights reserved.

Redistribution and use in source and binary forms, with or without modification, are permitted provided that the following conditions are met:

1. Redistributions of source code must retain the above copyright notice, this list of conditions and the following disclaimer.
2. Redistributions in binary form must reproduce the above copyright notice, this list of conditions and the following disclaimer in the documentation and/or other materials provided with the distribution.

THIS SOFTWARE IS PROVIDED BY THE AUTHOR "AS IS" AND ANY EXPRESS OR IMPLIED WARRANTIES, INCLUDING, BUT NOT LIMITED TO, THE IMPLIED WARRANTIES OF MERCHANTABILITY AND FITNESS FOR A PARTICULAR PURPOSE ARE DISCLAIMED. IN NO EVENT SHALL THE AUTHOR BE LIABLE FOR ANY DIRECT, INDIRECT, INCIDENTAL, SPECIAL, EXEMPLARY, OR CONSEQUENTIAL DAMAGES (INCLUDING, BUT NOT LIMITED TO, PROCUREMENT OF SUBSTITUTE GOODS OR SERVICES; LOSS OF USE, DATA, OR PROFITS; OR BUSINESS INTERRUPTION) HOWEVER CAUSED AND ON ANY THEORY OF LIABILITY, WHETHER IN CONTRACT, STRICT LIABILITY, OR TORT (INCLUDING NEGLIGENCE OR OTHERWISE) ARISING IN ANY WAY OUT OF THE USE OF THIS SOFTWARE, EVEN IF ADVISED OF THE POSSIBILITY OF SUCH DAMAGE.

Portions Copyright (c) 1987 Regents of the University of California. All rights reserved.

Redistribution and use in source and binary forms are permitted provided that the above copyright notice and this paragraph are duplicated in all such forms and that any documentation, advertising materials, and other materials related to such distribution and use acknowledge that the software was developed by the University of California, Berkeley. The name of the University may not be used to endorse or promote products derived from this software without specific prior written permission.

THIS SOFTWARE IS PROVIDED "AS IS" AND WITHOUT ANY EXPRESS OR IMPLIED WARRANTIES, INCLUDING, WITHOUT LIMITATION, THE IMPLIED WARRANTIES OF MERCHANTABILITY AND FITNESS FOR A PARTICULAR PURPOSE.

Copyright (c) 1990, 1991, 1992, 1993, 1994, 1995, 1996, 1997

The Regents of the University of California. All rights reserved.

This code is derived from the Stanford/CMU enet packet filter, (net/enet.c) distributed as part of 4.3BSD, and code contributed to Berkeley by Steven McCanne and Van Jacobson both of Lawrence Berkeley Laboratory.

Redistribution and use in source and binary forms, with or without modification, are permitted provided that the following conditions are met:

1. Redistributions of source code must retain the above copyright notice, this list of conditions and the following disclaimer.
2. Redistributions in binary form must reproduce the above copyright notice, this list of conditions and the following disclaimer in the documentation and/or other materials provided with the distribution.
3. All advertising materials mentioning features or use of this software must display the following acknowledgement:

This product includes software developed by the University of California, Berkeley and its contributors.

4. Neither the name of the University nor the names of its contributors may be used to endorse or promote products derived from this software without specific prior written permission.

THIS SOFTWARE IS PROVIDED BY THE REGENTS AND CONTRIBUTORS "AS IS" AND ANY EXPRESS OR IMPLIED WARRANTIES, INCLUDING, BUT NOT LIMITED TO, THE IMPLIED WARRANTIES OF MERCHANTABILITY AND FITNESS FOR A PARTICULAR PURPOSE ARE DISCLAIMED. IN NO EVENT SHALL THE REGENTS OR CONTRIBUTORS BE LIABLE FOR ANY DIRECT, INDIRECT, INCIDENTAL, SPECIAL, EXEMPLARY, OR CONSEQUENTIAL DAMAGES (INCLUDING, BUT NOT LIMITED TO, PROCUREMENT OF SUBSTITUTE GOODS OR SERVICES; LOSS OF USE, DATA, OR PROFITS; OR BUSINESS INTERRUPTION) HOWEVER CAUSED AND ON ANY THEORY OF LIABILITY, WHETHER IN CONTRACT, STRICT LIABILITY, OR TORT (INCLUDING NEGLIGENCE OR OTHERWISE) ARISING IN ANY WAY OUT OF THE USE OF THIS SOFTWARE, EVEN IF ADVISED OF THE POSSIBILITY OF SUCH DAMAGE.

Copyright (c) 1982, 1986 Regents of the University of California. All rights reserved.

Redistribution and use in source and binary forms are permitted provided that the above copyright notice and this paragraph are duplicated in all such forms and that any documentation, advertising materials, and other materials related to such distribution and use acknowledge that the software was developed by the University of California, Berkeley. The name of the University may not be used to endorse or promote products derived from this software without specific prior written permission.

THIS SOFTWARE IS PROVIDED "AS IS" AND WITHOUT ANY EXPRESS OR IMPLIED WARRANTIES, INCLUDING, WITHOUT LIMITATION, THE IMPLIED WARRANTIES OF MERCHANTABILITY AND FITNESS FOR A PARTICULAR PURPOSE.

Copyright (c) 1997-2001 University of Cambridge

University of Cambridge Computing Service, Cambridge, England. Phone: +44 1223 334714.

Permission is granted to anyone to use this software for any purpose on any computer system, and to redistribute it freely, subject to the following restrictions:

1. This software is distributed in the hope that it will be useful, but WITHOUT ANY WARRANTY; without even the implied warranty of MERCHANTABILITY or FITNESS FOR A PARTICULAR PURPOSE.
2. The origin of this software must not be misrepresented, either by explicit claim or by omission. In practice, this means that if you use PCRE in software which you distribute to others, commercially or otherwise, you must put a sentence like this

Regular expression support is provided by the PCRE library package, which is open source software, written by Philip Hazel, and copyright by the University of Cambridge, England.

somewhere reasonably visible in your documentation and in any relevant files or online help data or similar. A reference to the ftp site for the source, that is, to

<ftp://ftp.csx.cam.ac.uk/pub/software/programming/pcre/>

should also be given in the documentation.

3. Altered versions must be plainly marked as such, and must not be misrepresented as being the original software.
 4. If PCRE is embedded in any software that is released under the GNU General Purpose Licence (GPL), or Lesser General Purpose Licence (LGPL), then the terms of that licence shall supersede any condition above with which it is incompatible.
-

Copyright (c) 1996 by Internet Software Consortium.

Permission to use, copy, modify, and distribute this software for any purpose with or without fee is hereby granted, provided that the above copyright notice and this permission notice appear in all copies.

THE SOFTWARE IS PROVIDED "AS IS" AND INTERNET SOFTWARE CONSORTIUM DISCLAIMS ALL WARRANTIES WITH REGARD TO THIS SOFTWARE INCLUDING ALL IMPLIED WARRANTIES OF MERCHANTABILITY AND FITNESS. IN NO EVENT SHALL INTERNET SOFTWARE CONSORTIUM BE LIABLE FOR ANY SPECIAL, DIRECT, INDIRECT, OR CONSEQUENTIAL DAMAGES OR ANY DAMAGES WHATSOEVER RESULTING FROM LOSS OF USE, DATA OR PROFITS, WHETHER IN AN ACTION OF CONTRACT, NEGLIGENCE OR OTHER TORTIOUS ACTION, ARISING OUT OF OR IN CONNECTION WITH THE USE OR PERFORMANCE OF THIS SOFTWARE.

Portions Copyright (c) 1995 by International Business Machines, Inc.

International Business Machines, Inc. (hereinafter called IBM) grants permission under its copyrights to use, copy, modify, and distribute this Software with or without fee, provided that the above copyright notice and all paragraphs of this notice appear in all copies, and that the name of IBM not be used in connection with the marketing of any product incorporating the Software or modifications thereof, without specific, written prior permission.

To the extent it has a right to do so, IBM grants an immunity from suit under its patents, if any, for the use, sale or manufacture of products to the extent that such products are used for performing Domain Name System dynamic updates in TCP/IP networks by means of the Software. No immunity is granted for any product per se or for any other function of any product.

THE SOFTWARE IS PROVIDED "AS IS", AND IBM DISCLAIMS ALL WARRANTIES, INCLUDING ALL IMPLIED WARRANTIES OF MERCHANTABILITY AND FITNESS FOR A PARTICULAR PURPOSE. IN NO EVENT SHALL IBM BE LIABLE FOR ANY SPECIAL, DIRECT, INDIRECT, OR CONSEQUENTIAL DAMAGES OR ANY DAMAGES WHATSOEVER ARISING OUT OF OR IN CONNECTION WITH THE USE OR PERFORMANCE OF THIS SOFTWARE, EVEN IF IBM IS APPRISED OF THE POSSIBILITY OF SUCH DAMAGES.

Copyright (c) 1984, 1989, William LeFebvre, Rice University

Copyright (c) 1989 - 1994, William LeFebvre, Northwestern University

Copyright (c) 1994, 1995, William LeFebvre, Argonne National Laboratory

Copyright (c) 1996, William LeFebvre, Group sys Consulting

Copyright (c) 1995, 1996, 1997

The Regents of the University of California. All rights reserved.

Redistribution and use in source and binary forms, with or without modification, are permitted provided that: (1) source code distributions retain the above copyright notice and this paragraph in its entirety, (2) distributions including binary code include the above copyright notice and this paragraph in its entirety in the documentation or other materials provided with the distribution, and (3) all advertising materials mentioning features or use of this software display the following acknowledgement: "This product includes software developed by the University of California, Lawrence Berkeley Laboratory and its contributors." Neither the name of the University nor the names of its contributors may be used to endorse or promote products derived from this software without specific prior written permission.

THIS SOFTWARE IS PROVIDED "AS IS" AND WITHOUT ANY EXPRESS OR IMPLIED WARRANTIES, INCLUDING, WITHOUT LIMITATION, THE IMPLIED WARRANTIES OF MERCHANTABILITY AND FITNESS FOR A PARTICULAR PURPOSE.

Copyright (c) 1995 Tatu Ylonen <ylo@cs.hut.fi>, Espoo, Finland. All rights reserved

As far as I am concerned, the code I have written for this software can be used freely for any purpose. Any derived versions of this software must be clearly marked as such, and if the derived work is incompatible with the protocol description in the RFC file, it must be called by a name other than "ssh" or "Secure Shell".

Copyright (c) 1999 Niels Provos. All rights reserved.

Copyright (c) 1999, 2000 Markus Friedl. All rights reserved.

Redistribution and use in source and binary forms, with or without modification, are permitted provided that the following conditions are met:

1. Redistributions of source code must retain the above copyright notice, this list of conditions and the following disclaimer.
2. Redistributions in binary form must reproduce the above copyright notice, this list of conditions and the following disclaimer in the documentation and/or other materials provided with the distribution.

THIS SOFTWARE IS PROVIDED BY THE AUTHOR "AS IS" AND ANY EXPRESS OR IMPLIED WARRANTIES, INCLUDING, BUT NOT LIMITED TO, THE IMPLIED WARRANTIES OF MERCHANTABILITY AND FITNESS FOR A PARTICULAR PURPOSE ARE DISCLAIMED. IN NO EVENT SHALL THE AUTHOR BE LIABLE FOR ANY DIRECT, INDIRECT, INCIDENTAL, SPECIAL, EXEMPLARY, OR CONSEQUENTIAL DAMAGES (INCLUDING, BUT NOT LIMITED TO, PROCUREMENT OF SUBSTITUTE GOODS OR SERVICES; LOSS OF USE, DATA, OR PROFITS; OR BUSINESS INTERRUPTION) HOWEVER CAUSED AND ON ANY THEORY OF LIABILITY, WHETHER IN CONTRACT, STRICT LIABILITY, OR TORT (INCLUDING NEGLIGENCE OR OTHERWISE) ARISING IN ANY WAY OUT OF THE USE OF THIS SOFTWARE, EVEN IF ADVISED OF THE POSSIBILITY OF SUCH DAMAGE.

Copyright (c) 2000 Niels Provos. All rights reserved.

Redistribution and use in source and binary forms, with or without modification, are permitted provided that the following conditions are met:

1. Redistributions of source code must retain the above copyright notice, this list of conditions and the following disclaimer.
2. Redistributions in binary form must reproduce the above copyright notice, this list of conditions and the following disclaimer in the documentation and/or other materials provided with the distribution.

THIS SOFTWARE IS PROVIDED BY THE AUTHOR "AS IS" AND ANY EXPRESS OR IMPLIED WARRANTIES, INCLUDING, BUT NOT LIMITED TO, THE IMPLIED WARRANTIES OF MERCHANTABILITY AND FITNESS FOR A PARTICULAR PURPOSE ARE DISCLAIMED. IN NO EVENT SHALL THE AUTHOR BE LIABLE FOR ANY DIRECT, INDIRECT, INCIDENTAL, SPECIAL, EXEMPLARY, OR CONSEQUENTIAL DAMAGES (INCLUDING, BUT NOT LIMITED TO, PROCUREMENT OF SUBSTITUTE GOODS OR SERVICES; LOSS OF USE, DATA, OR PROFITS; OR BUSINESS INTERRUPTION) HOWEVER CAUSED AND ON ANY THEORY OF LIABILITY, WHETHER IN CONTRACT, STRICT LIABILITY, OR TORT (INCLUDING NEGLIGENCE OR OTHERWISE) ARISING IN ANY WAY OUT OF THE USE OF THIS SOFTWARE, EVEN IF ADVISED OF THE POSSIBILITY OF SUCH DAMAGE.

Copyright (c) 1998 Todd C. Miller <Todd.Miller@courtesan.com>. All rights reserved.

Redistribution and use in source and binary forms, with or without modification, are permitted provided that the following conditions are met:

1. Redistributions of source code must retain the above copyright notice, this list of conditions and the following disclaimer.
2. Redistributions in binary form must reproduce the above copyright notice, this list of conditions and the following disclaimer in the documentation and/or other materials provided with the distribution.
3. The name of the author may not be used to endorse or promote products derived from this software without specific prior written permission.

THIS SOFTWARE IS PROVIDED "AS IS" AND ANY EXPRESS OR IMPLIED WARRANTIES, INCLUDING, BUT NOT LIMITED TO, THE IMPLIED WARRANTIES OF MERCHANTABILITY AND FITNESS FOR A PARTICULAR PURPOSE ARE DISCLAIMED. IN NO EVENT SHALL THE AUTHOR BE LIABLE FOR ANY DIRECT, INDIRECT, INCIDENTAL, SPECIAL, EXEMPLARY, OR CONSEQUENTIAL DAMAGES (INCLUDING, BUT NOT LIMITED TO, PROCUREMENT OF SUBSTITUTE GOODS OR SERVICES; LOSS OF USE, DATA, OR PROFITS; OR BUSINESS INTERRUPTION) HOWEVER CAUSED AND ON ANY THEORY OF LIABILITY, WHETHER IN CONTRACT, STRICT LIABILITY, OR TORT (INCLUDING NEGLIGENCE OR OTHERWISE) ARISING IN ANY WAY OUT OF THE USE OF THIS SOFTWARE, EVEN IF ADVISED OF THE POSSIBILITY OF SUCH DAMAGE.

Copyright (C) 1999 Aladdin Enterprises. All rights reserved.

This software is provided 'as-is', without any express or implied warranty. In no event will the authors be held liable for any damages arising from the use of this software.

Permission is granted to anyone to use this software for any purpose, including commercial applications, and to alter it and redistribute it freely, subject to the following restrictions:

1. The origin of this software must not be misrepresented; you must not claim that you wrote the original software. If you use this software in a product, an acknowledgment in the product documentation would be appreciated but is not required.
 2. Altered source versions must be plainly marked as such, and must not be misrepresented as being the original software.
 3. This notice may not be removed or altered from any source distribution.
-

Independent implementation of MD5 (RFC 1321).

This code implements the MD5 Algorithm defined in RFC 1321. It is derived directly from the text of the RFC and not from the reference implementation.

The original and principal author of md5.c is L. Peter Deutsch <ghost@aladdin.com>. Other authors are noted in the change history that follows (in reverse chronological order):

1999-11-04 lpd Edited comments slightly for automatic TOC extraction.

1999-10-18 lpd Fixed typo in header comment (ansi2knr rather than md5).

1999-05-03 lpd Original version.

Copyright (c) 1994, 1996

The Regents of the University of California. All rights reserved.

Redistribution and use in source and binary forms are permitted provided that this notice is preserved and that due credit is given to the University of California at Berkeley. The name of the University may not be used to endorse or promote products derived from this software without specific prior written permission. This software is provided "as is" without express or implied warranty.

Copyright (c) 1988, 1989, 1990, 1991, 1992, 1995, 1996, 1997

The Regents of the University of California. All rights reserved.

Redistribution and use in source and binary forms, with or without modification, are permitted provided that: (1) source code distributions retain the above copyright notice and this paragraph in its entirety, (2) distributions including binary code include the above copyright notice and this paragraph in its entirety in the documentation or other materials provided with the distribution, and (3) all advertising materials mentioning features or use of this software display the following acknowledgement:

"This product includes software developed by the University of California, Lawrence Berkeley Laboratory and its contributors."

Neither the name of the University nor the names of its contributors may be used to endorse or promote products derived from this software without specific prior written permission.

THIS SOFTWARE IS PROVIDED "AS IS" AND WITHOUT ANY EXPRESS OR IMPLIED WARRANTIES, INCLUDING, WITHOUT LIMITATION, THE IMPLIED WARRANTIES OF MERCHANTABILITY AND FITNESS FOR A PARTICULAR PURPOSE.

Copyright (C) 2002 Bruce Allen <smartmontools-support@lists.sourceforge.net>

This program is free software; you can redistribute it and/or modify it under the terms of the GNU General Public License as published by the Free Software Foundation; either version 2, or (at your option) any later version.

You should have received a copy of the GNU General Public License (for example COPYING); if not, write to the Free Software Foundation, Inc., 675 Mass Ave, Cambridge, MA 02139, USA.

This code was originally developed as a Senior Thesis by Michael Cornwell at the Concurrent Systems Laboratory (now part of the Storage Systems Research Center), Jack Baskin School of Engineering, University of California, Santa Cruz.
<http://ssrc.soe.ucsc.edu/>

Copyright (C) 1985-2003 by the Massachusetts Institute of Technology. All rights reserved.

Export of this software from the United States of America may require a specific license from the United States Government. It is the responsibility of any person or organization contemplating export to obtain such a license before exporting.

WITHIN THAT CONSTRAINT, permission to use, copy, modify, and distribute this software and its documentation for any purpose and without fee is hereby granted, provided that the above copyright notice appear in all copies and that both that copyright notice and this permission notice appear in supporting documentation, and that the name of M.I.T. not be used in advertising or publicity pertaining to distribution of the software without specific, written prior permission. Furthermore if you modify this software you must label your software as modified software and not distribute it in such a fashion that it might be confused with the original MIT software. M.I.T. makes no representations about the suitability of this software for any purpose. It is provided "as is" without express or implied warranty.

THIS SOFTWARE IS PROVIDED "AS IS" AND WITHOUT ANY EXPRESS OR IMPLIED WARRANTIES, INCLUDING, WITHOUT LIMITATION, THE IMPLIED WARRANTIES OF MERCHANTABILITY AND FITNESS FOR A PARTICULAR PURPOSE.

Individual source code files are copyright MIT, Cygnus Support, OpenVision, Oracle, Sun Soft, FundsXpress, and others.

Project Athena, Athena, Athena MUSE, Discuss, Hesiod, Kerberos, Moira, and Zephyr are trademarks of the Massachusetts Institute of Technology (MIT). No commercial use of these trademarks may be made without prior written permission of MIT.

"Commercial use" means use of a name in a product or other for-profit manner. It does NOT prevent a commercial firm from referring to the MIT trademarks in order to convey information (although in doing so, recognition of their trademark status should be given).

Copyright, OpenVision Technologies, Inc., 1996, All Rights Reserved

WARNING: Retrieving the OpenVision Kerberos Administration system source code, as described below, indicates your acceptance of the following terms. If you do not agree to the following terms, do not retrieve the OpenVision Kerberos administration system.

You may freely use and distribute the Source Code and Object Code compiled from it, with or without modification, but this Source Code is provided to you "AS IS" EXCLUSIVE OF ANY WARRANTY, INCLUDING, WITHOUT LIMITATION, ANY WARRANTIES OF MERCHANTABILITY OR FITNESS FOR A PARTICULAR PURPOSE, OR ANY OTHER WARRANTY, WHETHER EXPRESS OR IMPLIED. IN NO EVENT WILL OPENVISION HAVE ANY LIABILITY FOR ANY LOST PROFITS, LOSS OF DATA OR COSTS OF PROCUREMENT OF SUBSTITUTE GOODS OR SERVICES, OR FOR ANY SPECIAL, INDIRECT, OR CONSEQUENTIAL DAMAGES ARISING OUT OF THIS AGREEMENT, INCLUDING, WITHOUT LIMITATION, THOSE RESULTING FROM THE USE OF THE SOURCE CODE, OR THE FAILURE OF THE SOURCE CODE TO PERFORM, OR FOR ANY OTHER REASON.

OpenVision retains all copyrights in the donated Source Code. OpenVision also retains copyright to derivative works of the Source Code, whether created by OpenVision or by a third party. The OpenVision copyright notice must be preserved if derivative works are made based on the donated Source Code.

OpenVision Technologies, Inc. has donated this Kerberos Administration system to MIT for inclusion in the standard Kerberos 5 distribution. This donation underscores our commitment to continuing Kerberos technology development and our gratitude for the valuable work which has been performed by MIT and the Kerberos community.

Portions contributed by Matt Crawford <crawdad@fnal.gov> were work performed at Fermi National Accelerator Laboratory, which is operated by Universities Research Association, Inc., under contract DE-AC02-76CHO3000 with the U.S. Department of Energy.

Copyright 2000 by Zero-Knowledge Systems, Inc.

Permission to use, copy, modify, distribute, and sell this software and its documentation for any purpose is hereby granted without fee, provided that the above copyright notice appear in all copies and that both that copyright notice and this permission notice appear in supporting documentation, and that the name of Zero-Knowledge Systems, Inc. not be used in advertising or publicity pertaining to distribution of the software without specific, written prior permission. Zero-Knowledge Systems, Inc. makes no representations about the suitability of this software for any purpose. It is provided "as is" without express or implied warranty.

ZERO-KNOWLEDGE SYSTEMS, INC. DISCLAIMS ALL WARRANTIES WITH REGARD TO THIS SOFTWARE, INCLUDING ALL IMPLIED WARRANTIES OF MERCHANTABILITY AND FITNESS, IN NO EVENT SHALL ZERO-KNOWLEDGE SYSTEMS, INC. BE LIABLE FOR ANY SPECIAL, INDIRECT OR CONSEQUENTIAL DAMAGES OR ANY DAMAGES WHATSOEVER RESULTING FROM LOSS OF USE, DATA OR PROFITS, WHETHER IN AN ACTION OF CONTRACT, NEGLIGENCE OR OTHER TORTUOUS ACTION, ARISING OUT OF OR IN CONNECTION WITH THE USE OR PERFORMANCE OF THIS SOFTWARE.

Copyright (c) 2001, Dr Brian Gladman <brg@gladman.uk.net>, Worcester, UK. All rights reserved.

LICENSE TERMS The free distribution and use of this software in both source and binary form is allowed (with or without changes) provided that:

1. distributions of this source code include the above copyright notice, this list of conditions and the following disclaimer;
2. distributions in binary form include the above copyright notice, this list of conditions and the following disclaimer in the documentation and/or other associated materials;
3. the copyright holder's name is not used to endorse products built using this software without specific written permission.

DISCLAIMER

This software is provided "as is" with no explicit or implied warranties in respect of any properties, including, but not limited to, correctness and fitness for purpose.

Copyright (C) 2002 Bruce Allen <smartmontools-support@lists.sourceforge.net>

This program is free software; you can redistribute it and/or modify it under the terms of the GNU General Public License as published by the Free Software Foundation; either version 2, or (at your option) any later version.

You should have received a copy of the GNU General Public License (for example COPYING); if not, write to the Free Software Foundation, Inc., 675 Mass Ave, Cambridge, MA 02139, USA.

This code was originally developed as a Senior Thesis by Michael Cornwell at the Concurrent Systems Laboratory (now part of the Storage Systems Research Center), Jack Baskin School of Engineering, University of California, Santa Cruz.

<http://src.soe.ucsc.edu/>

Copyright (c) 1996 - 2006, Daniel Stenberg, <daniel@haxx.se>.

All rights reserved.

Permission to use, copy, modify, and distribute this software for any purpose with or without fee is hereby granted, provided that the above copyright notice and this permission notice appear in all copies.

THE SOFTWARE IS PROVIDED "AS IS", WITHOUT WARRANTY OF ANY KIND, EXPRESS OR IMPLIED, INCLUDING BUT NOT LIMITED TO THE WARRANTIES OF MERCHANTABILITY, FITNESS FOR A PARTICULAR PURPOSE AND NONINFRINGEMENT OF THIRD PARTY RIGHTS. IN NO EVENT SHALL THE AUTHORS OR COPYRIGHT HOLDERS BE LIABLE FOR ANY CLAIM, DAMAGES OR OTHER LIABILITY, WHETHER IN AN ACTION OF CONTRACT, TORT OR OTHERWISE, ARISING FROM, OUT OF OR IN CONNECTION WITH THE SOFTWARE OR THE USE OR OTHER DEALINGS IN THE SOFTWARE.

Except as contained in this notice, the name of a copyright holder shall not be used in advertising or otherwise to promote the sale, use or other dealings in this Software without prior written authorization of the copyright holder.

Copyright (c) 1998-2003 Carnegie Mellon University. All rights reserved.

Redistribution and use in source and binary forms, with or without modification, are permitted provided that the following conditions are met:

1. Redistributions of source code must retain the above copyright notice, this list of conditions and the following disclaimer.
2. Redistributions in binary form must reproduce the above copyright notice, this list of conditions and the following disclaimer in the documentation and/or other materials provided with the distribution.
3. The name "Carnegie Mellon University" must not be used to endorse or promote products derived from this software without prior written permission. For permission or any other legal details, please contact

Office of Technology Transfer
Carnegie Mellon University
5000 Forbes Avenue
Pittsburgh, PA 15213-3890
(412) 268-4387, fax: (412) 268-7395
tech-transfer@andrew.cmu.edu

4. Redistributions of any form whatsoever must retain the following acknowledgment: "This product includes software developed by Computing Services at Carnegie Mellon University (<http://www.cmu.edu/computing/>).

CARNEGIE MELLON UNIVERSITY DISCLAIMS ALL WARRANTIES WITH REGARD TO THIS SOFTWARE, INCLUDING ALL IMPLIED WARRANTIES OF MERCHANTABILITY AND FITNESS, IN NO EVENT SHALL CARNEGIE MELLON UNIVERSITY BE LIABLE FOR ANY SPECIAL, INDIRECT OR CONSEQUENTIAL DAMAGES OR ANY DAMAGES WHATSOEVER RESULTING FROM LOSS OF USE, DATA OR PROFITS, WHETHER IN AN ACTION OF CONTRACT, NEGLIGENCE OR OTHER TORTIOUS ACTION, ARISING OUT OF OR IN CONNECTION WITH THE USE OR PERFORMANCE OF THIS SOFTWARE.

Copyright (C) 1999-2008 Dieter Baron and Thomas Klausner

This file is part of libzip, a library to manipulate ZIP archives. The authors can be contacted at <libzip@nih.at>

Redistribution and use in source and binary forms, with or without modification, are permitted provided that the following conditions are met:

1. Redistributions of source code must retain the above copyright notice, this list of conditions and the following disclaimer.
2. Redistributions in binary form must reproduce the above copyright notice, this list of conditions and the following disclaimer in the documentation and/or other materials provided with the distribution.
3. The names of the authors may not be used to endorse or promote products derived from this software without specific prior written permission.

THIS SOFTWARE IS PROVIDED BY THE AUTHORS "AS IS" AND ANY EXPRESS OR IMPLIED WARRANTIES, INCLUDING, BUT NOT LIMITED TO, THE IMPLIED WARRANTIES OF MERCHANTABILITY AND FITNESS FOR A PARTICULAR PURPOSE ARE DISCLAIMED. IN NO EVENT SHALL THE AUTHORS BE LIABLE FOR ANY DIRECT, INDIRECT, INCIDENTAL, SPECIAL, EXEMPLARY, OR CONSEQUENTIAL DAMAGES (INCLUDING, BUT NOT LIMITED TO, PROCUREMENT OF SUBSTITUTE GOODS OR SERVICES; LOSS OF USE, DATA, OR PROFITS; OR BUSINESS INTERRUPTION) HOWEVER CAUSED AND ON ANY THEORY OF LIABILITY, WHETHER IN CONTRACT, STRICT LIABILITY, OR TORT (INCLUDING NEGLIGENCE OR OTHERWISE) ARISING IN ANY WAY OUT OF THE USE OF THIS SOFTWARE, EVEN IF ADVISED OF THE POSSIBILITY OF SUCH DAMAGE.

Copyright 1998-2002 University of Illinois Board of Trustees

Copyright 1998-2002 Mark D. Roth

All rights reserved.

libtar_hash.c - hash table routines

Mark D. Roth <roth@uiuc.edu>

Campus Information Technologies and Educational Services

University of Illinois at Urbana-Champaign

Flasm, command line assembler & disassembler of Flash ActionScript bytecode

Copyright (c) 2001 Opaque Industries, (c) 2002-2007 Igor Kogan, (c) 2005 Wang Zhen

All rights reserved.

Redistribution and use in source and binary forms, with or without modification, are permitted provided that the following conditions are met:

- * Redistributions of source code must retain the above copyright notice, this list of conditions and the following disclaimer.
- * Redistributions in binary form must reproduce the above copyright notice, this list of conditions and the following disclaimer in the documentation and/or other materials provided with the distribution.

* Neither the name of the Opaque Industries nor the names of its contributors may be used to endorse or promote products derived from this software without specific prior written permission.

THIS SOFTWARE IS PROVIDED BY THE COPYRIGHT HOLDERS AND CONTRIBUTORS "AS IS" AND ANY EXPRESS OR IMPLIED WARRANTIES, INCLUDING, BUT NOT LIMITED TO, THE IMPLIED WARRANTIES OF MERCHANTABILITY AND FITNESS FOR A PARTICULAR PURPOSE ARE DISCLAIMED. IN NO EVENT SHALL THE COPYRIGHT OWNER OR CONTRIBUTORS BE LIABLE FOR ANY DIRECT, INDIRECT, INCIDENTAL, SPECIAL, EXEMPLARY, OR CONSEQUENTIAL DAMAGES (INCLUDING, BUT NOT LIMITED TO, PROCUREMENT OF SUBSTITUTE GOODS OR SERVICES; LOSS OF USE, DATA, OR PROFITS; OR BUSINESS INTERRUPTION) HOWEVER CAUSED AND ON ANY THEORY OF LIABILITY, WHETHER IN CONTRACT, STRICT LIABILITY, OR TORT (INCLUDING NEGLIGENCE OR OTHERWISE) ARISING IN ANY WAY OUT OF THE USE OF THIS SOFTWARE, EVEN IF ADVISED OF THE POSSIBILITY OF SUCH DAMAGE.

Macromedia and Flash are either registered trademarks or trademarks of Adobe Systems Incorporated in the United States and/or other countries.

Adobe does not sponsor, affiliate, or endorse this product and/or services.

Copyright (C) 2006-2010, Rapid7 LLC

All rights reserved.

Redistribution and use in source and binary forms, with or without modification, are permitted provided that the following conditions are met:

- * Redistributions of source code must retain the above copyright notice, this list of conditions and the following disclaimer.
- * Redistributions in binary form must reproduce the above copyright notice, this list of conditions and the following disclaimer in the documentation and/or other materials provided with the distribution.
- * Neither the name of Rapid7 LLC nor the names of its contributors may be used to endorse or promote products derived from this software without specific prior written permission.

THIS SOFTWARE IS PROVIDED BY THE COPYRIGHT HOLDERS AND CONTRIBUTORS "AS IS" AND ANY EXPRESS OR IMPLIED WARRANTIES, INCLUDING, BUT NOT LIMITED TO, THE IMPLIED WARRANTIES OF MERCHANTABILITY AND FITNESS FOR A PARTICULAR PURPOSE ARE DISCLAIMED. IN NO EVENT SHALL THE COPYRIGHT OWNER OR CONTRIBUTORS BE LIABLE FOR ANY DIRECT, INDIRECT, INCIDENTAL, SPECIAL, EXEMPLARY, OR CONSEQUENTIAL DAMAGES (INCLUDING, BUT NOT LIMITED TO, PROCUREMENT OF SUBSTITUTE GOODS OR SERVICES; LOSS OF USE, DATA, OR PROFITS; OR BUSINESS INTERRUPTION) HOWEVER CAUSED AND ON ANY THEORY OF LIABILITY, WHETHER IN CONTRACT, STRICT LIABILITY, OR TORT (INCLUDING NEGLIGENCE OR OTHERWISE) ARISING IN ANY WAY OUT OF THE USE OF THIS SOFTWARE, EVEN IF ADVISED OF THE POSSIBILITY OF SUCH DAMAGE.

=====

The Metasploit Framework is provided under the 3-clause BSD license above.

The copyright on this package is held by Rapid7 LLC.

This license does not apply to the following components:

- The OpenSSL library embedded into the Meterpreter payload binaries and the corresponding header files in the source tree
- The Packet Sniffer SDK (MicroOLAP) library embedded into the Meterpreter Sniffer extension. HD Moore has a single-seat developer license.
- The modified TightVNC binaries and their associated source code.
- The icons used by msfweb that were not created by Metasploit
- The Bit-Struct library located under lib/bit-struct
- The Byakugan plugin located under external/source/byakugan
- The Metasm library located under lib/metasm
- The PcapRub library located under external/pcaprub
- The Rabal library located under lib/rabal

Appendix D — Credits

- The Racket library located under lib/racket
- The Ruby-Lorcon library located under external/ruby-lorcon
- The SNMP library located under lib/snmp
- The Zip library located under lib/zip

The latest version of this software is available from <http://metasploit.com/>

Bug tracking and development information can be found at:
<http://www.metasploit.com/redmine/projects/framework/>

Questions and suggestions can be sent to:
[msfdev\[at\]metasploit.com](mailto:msfdev[at]metasploit.com)

The framework mailing list is the place to discuss features and ask for help.
To subscribe, visit the following web page:
<https://mail.metasploit.com/mailman/listinfo/framework>

The archives are available from:
<https://mail.metasploit.com/pipermail/framework/>

GNU LESSER GENERAL PUBLIC LICENSE

Version 2.1, February 1999

Copyright (C) 1991, 1999 Free Software Foundation, Inc.

59 Temple Place, Suite 330, Boston, MA 02111-1307 USA

Everyone is permitted to copy and distribute verbatim copies
of this license document, but changing it is not allowed.

[This is the first released version of the Lesser GPL. It also counts
as the successor of the GNU Library Public License, version 2, hence
the version number 2.1.]

Preamble

The licenses for most software are designed to take away your freedom to share and change it. By contrast, the GNU General Public Licenses are intended to guarantee your freedom to share and change free software--to make sure the software is free for all its users.

This license, the Lesser General Public License, applies to some specially designated software packages--typically libraries--of the Free Software Foundation and other authors who decide to use it. You can use it too, but we suggest you first think carefully about whether this license or the ordinary General Public License is the better strategy to use in any particular case, based on the explanations below.

When we speak of free software, we are referring to freedom of use, not price. Our General Public Licenses are designed to make sure that you have the freedom to distribute copies of free software (and charge for this service if you wish); that you receive source code or can get it if you want it; that you can change the software and use pieces of it in new free programs; and that you are informed that you can do these things.

To protect your rights, we need to make restrictions that forbid distributors to deny you these rights or to ask you to surrender these rights. These restrictions translate to certain responsibilities for you if you distribute copies of the library or if you modify it.

For example, if you distribute copies of the library, whether gratis or for a fee, you must give the recipients all the rights that we gave you. You must make sure that they, too, receive or can get the source code. If you link other code with the library, you must provide complete object files to the recipients, so that they can relink them with the library after making changes to the library and recompiling it. And you must show them these terms so they know their rights.

We protect your rights with a two-step method: (1) we copyright the library, and (2) we offer you this license, which gives you legal permission to copy, distribute and/or modify the library.

To protect each distributor, we want to make it very clear that there is no warranty for the free library. Also, if the library is modified by someone else and passed on, the recipients should know that what they have is not the original version, so that the original author's reputation will not be affected by problems that might be introduced by others.

Finally, software patents pose a constant threat to the existence of any free program. We wish to make sure that a company cannot effectively restrict the users of a free program by obtaining a restrictive license from a patent holder. Therefore, we insist that any patent license obtained for a version of the library must be consistent with the full freedom of use specified in this license.

Most GNU software, including some libraries, is covered by the ordinary GNU General Public License. This license, the GNU Lesser General Public License, applies to certain designated libraries, and is quite different from the ordinary General Public License. We use this license for certain libraries in order to permit linking those libraries into non-free programs.

When a program is linked with a library, whether statically or using a shared library, the combination of the two is legally speaking a combined work, a derivative of the original library. The ordinary General Public License therefore permits such linking only if the entire combination fits its criteria of freedom. The Lesser General Public License permits more lax criteria for linking other code with the library.

We call this license the "Lesser" General Public License because it does Less to protect the user's freedom than the ordinary General Public License. It also provides other free software developers Less of an advantage over competing non-free programs. These disadvantages are the reason we use the ordinary General Public License for many libraries. However, the Lesser license provides advantages in certain special circumstances.

For example, on rare occasions, there may be a special need to encourage the widest possible use of a certain library, so that it becomes a de-facto standard. To achieve this, non-free programs must be allowed to use the library. A more frequent case is that a free library does the same job as widely used non-free libraries. In this case, there is little to gain by limiting the free library to free software only, so we use the Lesser General Public License.

In other cases, permission to use a particular library in non-free programs enables a greater number of people to use a large body of free software. For example, permission to use the GNU C Library in non-free programs enables many more people to use the whole GNU operating system, as well as its variant, the GNU/Linux operating system.

Although the Lesser General Public License is Less protective of the users' freedom, it does ensure that the user of a program that is linked with the Library has the freedom and the wherewithal to run that program using a modified version of the Library.

The precise terms and conditions for copying, distribution and modification follow. Pay close attention to the difference between a "work based on the library" and a "work that uses the library". The former contains code derived from the library, whereas the latter must be combined with the library in order to run.

GNU LESSER GENERAL PUBLIC LICENSE

TERMS AND CONDITIONS FOR COPYING, DISTRIBUTION AND MODIFICATION

0. This License Agreement applies to any software library or other program which contains a notice placed by the copyright holder or other authorized party saying it may be distributed under the terms of this Lesser General Public License (also called "this License"). Each licensee is addressed as "you".

A "library" means a collection of software functions and/or data prepared so as to be conveniently linked with application programs (which use some of those functions and data) to form executables.

The "Library", below, refers to any such software library or work which has been distributed under these terms. A "work based on the Library" means either the Library or any derivative work under copyright law: that is to say, a work containing the Library or a portion of it, either verbatim or with modifications and/or translated straightforwardly into another language. (Hereinafter, translation is included without limitation in the term "modification".)

"Source code" for a work means the preferred form of the work for making modifications to it. For a library, complete source code means all the source code for all modules it contains, plus any associated interface definition files, plus the scripts used to control compilation and installation of the library.

Activities other than copying, distribution and modification are not covered by this License; they are outside its scope. The act of running a program using the Library is not restricted, and output from such a program is covered only if its contents constitute a work based on the Library (independent of the use of the Library in a tool for writing it). Whether that is true depends on what the Library does and what the program that uses the Library does.

1. You may copy and distribute verbatim copies of the Library's complete source code as you receive it, in any medium, provided that you conspicuously and appropriately publish on each copy an appropriate copyright notice and disclaimer of warranty; keep intact all the notices that refer to this License and to the absence of any warranty; and distribute a copy of this License along with the Library.

You may charge a fee for the physical act of transferring a copy, and you may at your option offer warranty protection in exchange for a fee.

2. You may modify your copy or copies of the Library or any portion of it, thus forming a work based on the Library, and copy and distribute such modifications or work under the terms of Section 1 above, provided that you also meet all of these conditions:

- a) The modified work must itself be a software library.
- b) You must cause the files modified to carry prominent notices stating that you changed the files and the date of any change.
- c) You must cause the whole of the work to be licensed at no charge to all third parties under the terms of this License.
- d) If a facility in the modified Library refers to a function or a table of data to be supplied by an application program that uses the facility, other than as an argument passed when the facility is invoked, then you must make a good faith effort to ensure that, in the event an application does not supply such function or table, the facility still operates, and performs whatever part of its purpose remains meaningful.

(For example, a function in a library to compute square roots has a purpose that is entirely well-defined independent of the application. Therefore, Subsection 2d requires that any application-supplied function or table used by this function must be optional: if the application does not supply it, the square root function must still compute square roots.)

These requirements apply to the modified work as a whole. If identifiable sections of that work are not derived from the Library, and can be reasonably considered independent and separate works in themselves, then this License, and its terms, do not apply to those sections when you distribute them as separate works. But when you distribute the same sections as part of a whole which is a work based on the Library, the distribution of the whole must be on the terms of this License, whose permissions for other licensees extend to the entire whole, and thus to each and every part regardless of who wrote it.

Thus, it is not the intent of this section to claim rights or contest your rights to work written entirely by you; rather, the intent is to exercise the right to control the distribution of derivative or collective works based on the Library.

In addition, mere aggregation of another work not based on the Library with the Library (or with a work based on the Library) on a volume of a storage or distribution medium does not bring the other work under the scope of this License.

3. You may opt to apply the terms of the ordinary GNU General Public License instead of this License to a given copy of the Library. To do this, you must alter all the notices that refer to this License, so that they refer to the ordinary GNU General Public License, version 2, instead of to this License. (If a newer version than version 2 of the ordinary GNU General Public License has appeared, then you can specify that version instead if you wish.) Do not make any other change in these notices.

Once this change is made in a given copy, it is irreversible for that copy, so the ordinary GNU General Public License applies to all subsequent copies and derivative works made from that copy.

This option is useful when you wish to copy part of the code of the Library into a program that is not a library.

4. You may copy and distribute the Library (or a portion or derivative of it, under Section 2) in object code or executable form under the terms of Sections 1 and 2 above provided that you accompany it with the complete corresponding machine-readable source code, which must be distributed under the terms of Sections 1 and 2 above on a medium customarily used for software interchange.

If distribution of object code is made by offering access to copy from a designated place, then offering equivalent access to copy the source code from the same place satisfies the requirement to distribute the source code, even though third parties are not compelled to copy the source along with the object code.

5. A program that contains no derivative of any portion of the Library, but is designed to work with the Library by being compiled or linked with it, is called a “work that uses the Library”. Such a work, in isolation, is not a derivative work of the Library, and therefore falls outside the scope of this License.

However, linking a “work that uses the Library” with the Library creates an executable that is a derivative of the Library (because it contains portions of the Library), rather than a “work that uses the library”. The executable is therefore covered by this License. Section 6 states terms for distribution of such executables.

When a “work that uses the Library” uses material from a header file that is part of the Library, the object code for the work may be a derivative work of the Library even though the source code is not. Whether this is true is especially significant if the work can be linked without the Library, or if the work is itself a library. The threshold for this to be true is not precisely defined by law.

If such an object file uses only numerical parameters, data structure layouts and accessors, and small macros and small inline functions (ten lines or less in length), then the use of the object file is unrestricted, regardless of whether it is legally a derivative work. (Executables containing this object code plus portions of the Library will still fall under Section 6.)

Otherwise, if the work is a derivative of the Library, you may distribute the object code for the work under the terms of Section 6. Any executables containing that work also fall under Section 6, whether or not they are linked directly with the Library itself.

6. As an exception to the Sections above, you may also combine or link a “work that uses the Library” with the Library to produce a work containing portions of the Library, and distribute that work under terms of your choice, provided that the terms permit modification of the work for the customer’s own use and reverse engineering for debugging such modifications.

You must give prominent notice with each copy of the work that the Library is used in it and that the Library and its use are covered by this License. You must supply a copy of this License. If the work during execution displays copyright notices, you must include the copyright notice for the Library among them, as well as a reference directing the user to the copy of this License. Also, you must do one of these things:

a) Accompany the work with the complete corresponding machine-readable source code for the Library including whatever changes were used in the work (which must be distributed under Sections 1 and 2 above); and, if the work is an executable linked with the Library, with the complete machine-readable “work that uses the Library”, as object code and/or source code, so that the user can modify the Library and then relink to produce a modified executable containing the modified Library. (It is understood that the user who changes the contents of definitions files in the Library will not necessarily be able to recompile the application to use the modified definitions.)

b) Use a suitable shared library mechanism for linking with the Library. A suitable mechanism is one that (1) uses at run time a copy of the library already present on the user's computer system, rather than copying library functions into the executable, and (2) will operate properly with a modified version of the library, if the user installs one, as long as the modified version is interface-compatible with the version that the work was made with.

c) Accompany the work with a written offer, valid for at least three years, to give the same user the materials specified in Subsection 6a, above, for a charge no more than the cost of performing this distribution.

d) If distribution of the work is made by offering access to copy from a designated place, offer equivalent access to copy the above specified materials from the same place.

e) Verify that the user has already received a copy of these materials or that you have already sent this user a copy.

For an executable, the required form of the “work that uses the Library” must include any data and utility programs needed for reproducing the executable from it. However, as a special exception, the materials to be distributed need not include anything that is normally distributed (in either source or binary form) with the major components (compiler, kernel, and so on) of the operating system on which the executable runs, unless that component itself accompanies the executable.

It may happen that this requirement contradicts the license restrictions of other proprietary libraries that do not normally accompany the operating system. Such a contradiction means you cannot use both them and the Library together in an executable that you distribute.

7. You may place library facilities that are a work based on the Library side-by-side in a single library together with other library facilities not covered by this License, and distribute such a combined library, provided that the separate distribution of the work based on the Library and of the other library facilities is otherwise permitted, and provided that you do these two things:

a) Accompany the combined library with a copy of the same work based on the Library, uncombined with any other library facilities. This must be distributed under the terms of the Sections above.

b) Give prominent notice with the combined library of the fact that part of it is a work based on the Library, and explaining where to find the accompanying uncombined form of the same work.

8. You may not copy, modify, sublicense, link with, or distribute the Library except as expressly provided under this License. Any attempt otherwise to copy, modify, sublicense, link with, or distribute the Library is void, and will automatically terminate your rights under this License. However, parties who have received copies, or rights, from you under this License will not have their licenses terminated so long as such parties remain in full compliance.

9. You are not required to accept this License, since you have not signed it. However, nothing else grants you permission to modify or distribute the Library or its derivative works. These actions are prohibited by law if you do not accept this License. Therefore, by modifying or distributing the Library (or any work based on the Library), you indicate your acceptance of this License to do so, and all its terms and conditions for copying, distributing or modifying the Library or works based on it.

10. Each time you redistribute the Library (or any work based on the Library), the recipient automatically receives a license from the original licensor to copy, distribute, link with or modify the Library subject to these terms and conditions. You may not impose any further restrictions on the recipients' exercise of the rights granted herein. You are not responsible for enforcing compliance by third parties with this License.

11. If, as a consequence of a court judgment or allegation of patent infringement or for any other reason (not limited to patent issues), conditions are imposed on you (whether by court order, agreement or otherwise) that contradict the conditions of this License, they do not excuse you from the conditions of this License. If you cannot distribute so as to satisfy simultaneously your obligations under this License and any other pertinent obligations, then as a consequence you may not distribute the Library at all. For example, if a patent license would not permit royalty-free redistribution of the Library by all those who receive copies directly or indirectly through you, then the only way you could satisfy both it and this License would be to refrain entirely from distribution of the Library.

If any portion of this section is held invalid or unenforceable under any particular circumstance, the balance of the section is intended to apply, and the section as a whole is intended to apply in other circumstances.

It is not the purpose of this section to induce you to infringe any patents or other property right claims or to contest validity of any such claims; this section has the sole purpose of protecting the integrity of the free software distribution system which is implemented by public license practices. Many people have made generous contributions to the wide range of software distributed through that system in reliance on consistent application of that system; it is up to the author/donor to decide if he or she is willing to distribute software through any other system and a licensee cannot impose that choice.

This section is intended to make thoroughly clear what is believed to be a consequence of the rest of this License.

12. If the distribution and/or use of the Library is restricted in certain countries either by patents or by copyrighted interfaces, the original copyright holder who places the Library under this License may add an explicit geographical distribution limitation excluding those countries, so that distribution is permitted only in or among countries not thus excluded. In such case, this License incorporates the limitation as if written in the body of this License.

13. The Free Software Foundation may publish revised and/or new versions of the Lesser General Public License from time to time. Such new versions will be similar in spirit to the present version, but may differ in detail to address new problems or concerns.

Each version is given a distinguishing version number. If the Library specifies a version number of this License which applies to it and "any later version", you have the option of following the terms and conditions either of that version or of any later version published by the Free Software Foundation. If the Library does not specify a license version number, you may choose any version ever published by the Free Software Foundation.

14. If you wish to incorporate parts of the Library into other free programs whose distribution conditions are incompatible with these, write to the author to ask for permission. For software which is copyrighted by the Free Software Foundation, write to the Free Software Foundation; we sometimes make exceptions for this. Our decision will be guided by the two goals of preserving the free status of all derivatives of our free software and of promoting the sharing and reuse of software generally.

NO WARRANTY

15. BECAUSE THE LIBRARY IS LICENSED FREE OF CHARGE, THERE IS NO WARRANTY FOR THE LIBRARY, TO THE EXTENT PERMITTED BY APPLICABLE LAW. EXCEPT WHEN OTHERWISE STATED IN WRITING THE COPYRIGHT HOLDERS AND/OR OTHER PARTIES PROVIDE THE LIBRARY "AS IS" WITHOUT WARRANTY OF ANY KIND, EITHER EXPRESSED OR IMPLIED, INCLUDING, BUT NOT LIMITED TO, THE IMPLIED WARRANTIES OF MERCHANTABILITY AND FITNESS FOR A PARTICULAR PURPOSE. THE ENTIRE RISK AS TO THE QUALITY AND PERFORMANCE OF THE LIBRARY IS WITH YOU. SHOULD THE LIBRARY PROVE DEFECTIVE, YOU ASSUME THE COST OF ALL NECESSARY SERVICING, REPAIR OR CORRECTION.

16. IN NO EVENT UNLESS REQUIRED BY APPLICABLE LAW OR AGREED TO IN WRITING WILL ANY COPYRIGHT HOLDER, OR ANY OTHER PARTY WHO MAY MODIFY AND/OR REDISTRIBUTE THE LIBRARY AS PERMITTED ABOVE, BE LIABLE TO YOU FOR DAMAGES, INCLUDING ANY GENERAL, SPECIAL, INCIDENTAL OR CONSEQUENTIAL DAMAGES ARISING OUT OF THE USE OR INABILITY TO USE THE LIBRARY (INCLUDING BUT NOT LIMITED TO LOSS OF DATA OR DATA BEING RENDERED INACCURATE OR LOSSES SUSTAINED BY YOU OR THIRD PARTIES OR A FAILURE OF THE LIBRARY TO OPERATE WITH ANY OTHER SOFTWARE), EVEN IF SUCH HOLDER OR OTHER PARTY HAS BEEN ADVISED OF THE POSSIBILITY OF SUCH DAMAGES.

Linking with OpenSSL

17. In addition, as a special exception, we give permission to link the code of its release of libssh with the OpenSSL project's "OpenSSL" library (or with modified versions of it that use the same license as the "OpenSSL" library), and distribute the linked executables. You must obey the GNU Lesser General Public License in all respects for all of the code used other than "OpenSSL". If you modify this file, you may extend this exception to your version of the file, but you are not obligated to do so. If you do not wish to do so, delete this exception statement from your version.

END OF TERMS AND CONDITIONS

A

- Activation Code/Network Err.message 74
- appliance
 - back panel 32
 - front panel 30
 - LAN port 32
 - LCD display and keypad 30
 - LEDs 31
 - WAN port 32
- arrow buttons 36

B

- back panel 32
- bandwidth, minimum 9
- bracket kit 8
- buttons on the LCD keypad 35

C

- Canceling the Ongoing Scan message 63
- Change Proxy Params option 53
- Communication Failure message 78
- configuration
 - changing 63
 - Ethernet port settings 60
 - Proxy support 51
 - reset network configuration 62
 - Scanner Appliance settings 24
 - split network 10, 56
 - static IP address 47
 - VLAN interface 45
- connectors 32

D

- Disable Proxy option 54
- Disable U/Passwd Store option 44

E

- Enable DHCP on WAN option 58
- Enable Proxy option 51
- Enable Static IP on LAN option 47
- Enable Static IP on WAN option 58
- Enable User/Passwd Store option 44
- Enable WAN interface option 57
- entering information
 - IP addresses 38
 - netmask entry 49
 - Proxy user fields 39, 40
 - QualysGuard user fields 38
 - selecting characters 36, 38
 - space character 37
 - using arrow buttons 36
- entry fields 36, 38
- error codes 74
- error messages
 - Activation Code/Network Err. 74
 - Communication Failure 78
 - Login to Qualys-Guard Web First 76
 - Network Error 74
- Ethernet LAN port 32
- Ethernet Port Settings option 60
- Ethernet WAN port 32
- Exit this Menu main menu option 35

F

- field entries 36
- firewalls 9
- front panel 30

G

- gateway IP address 47, 58
- grant user access to appliance 26

Index

H

HDD LED 31

I

interface maps 65

IP address for Scanner Appliance 18

IP addresses, entering in fields 38

L

LAN port 32

LCD display and keypad 16, 30

LCD interface 16, 30

LDC buttons 35

LEDs 31

login procedure 66

Login to Qualys-Guard Web First message 76

M

main menu options 34

 Disable U/Passwd Store 44

 Enable Proxy 51

 Enable User/Passwd Store 44

 Exit this Menu 35

 Reset Network Config 62

 Setup Network 34

 System Reboot 42

 System Shutdown 42

 Version Info 35

N

name 18

navigation 16

netmask 47, 49, 58

network configuration

 changing 63

 Ethernet port settings 60

 Proxy support 51

 reset 62

 split network 10, 56

 static IP address 47

 VLAN interface configuration 45

network error codes 74

Network Error message 74

network traffic connections 10

numeric field entries 36

O

operating environment 10

outbound HTTPS access 9

P

power requirement 10

primary DNS 48, 58

Proxy configuration 25, 51

proxy parameters

 configuration 51

 update 53

proxy password field 40, 52

proxy port 52

Proxy support 9

proxy user field 39, 52

PWR LED 31

Q

Qualys Support 5

Qualys user/password store 44

QualysGuard account 10, 15, 17, 44

QualysGuard user fields 36, 38

Quick Start 11

R

rack mount bracket kit 8

reboot system 42

replace scanner appliance workflow 27

Index

Reset Network Config option 62

S

S1 LED 31

Scanner Appliance

granting user access 26

IP address 16, 17, 18

login procedure 66

main menu 34

name 16, 17, 18

package contents 8

physical requirements 10

QualysGuard account 10

Quick Start 11

replace workflow 27

system software version 35

scanner appliance interface maps 65

Scanner Appliance name 16, 17

Scanner Appliance settings 24

scanning and firewalls 9

scans 9

scrolling through characters 36, 38

secondary DNS 48, 58

security audits 9

Setup Network main menu option 34

size requirement 10

space character 37

special characters 39, 40

split network configuration 10, 56

SSL bridging 51

SSL tunnel termination 51

static network parameters 47, 58

storage environment 10

System Reboot main menu option 42

system shutdown 18

System Shutdown main menu option 42

T

text field entries 36

troubleshooting

Activation Code/Network Err. message
74

Communication Failure message 78

Login to Qualys-Guard Web First message
76

Network Error message 74

U

user access to appliance 26

user/password store 44

V

Version Info main menu option 35

VLAN interface configuration 45

W

WAN port 32

